

**OPENING UP
THE SMART GRID**

**Factory Acceptance Tests
Results Documentation**



Report Title:	Factory Acceptance Tests – Results Documentation
Report Status:	Issued
Project Ref:	WPD/EN/NIC/02 – OpenLV
Date:	21.09.2017

Document Control

	Name	Date
Prepared by:	Tim Butler	September 2017
Reviewed by:	Richard Ash	September 2017
	Richard Potter	September 2017
Recommended by:	Dan Hollingworth	September 2017
Approved (WPD):	Mark Dale	September 2017

Revision History

Date	Issue	Status
21.09.2017	2.1	Not yet issued – pending FATs Part 2.
16.08.2017	1.0	Issued

DISCLAIMER

Neither WPD, nor any person acting on its behalf, makes any warranty, express or implied, with respect to the use of any information, method or process disclosed in this document or that such use may not infringe the rights of any third party or assumes any liabilities with respect to the use of, or for damage resulting in any way from the use of, any information, apparatus, method, or process disclosed in the document.

© Western Power Distribution 2017

No part of this publication may be reproduced, stored in a retrieval system or transmitted, in any form or by any means electronic, mechanical, photocopying, recording or otherwise, without the written permission of the Future Networks Manager, Western Power Distribution, Herald Way, Pegasus Business Park, Castle Donington. DE74 2TU.

Telephone +44 (0) 1332 827446. E-mail wpdinnovation@westernpower.co.uk

Contents

1	Introduction	5
1.1	Purpose.....	5
1.2	Scope	5
1.3	Environment.....	5
1.4	Test Data & Verification	5
2	Factory Acceptance Tests (FATs)	6
3	Factory Acceptance Tests – Part 1	7
3.1	Attendees	7
3.1.1	Western Power Distribution (WPD).....	7
3.1.2	EA Technology.....	7
3.1.3	Nortech Management Ltd.....	7
3.1.4	Lucy Electric	7
3.2	Setup Details	7
3.2.1	Login details	7
3.3	Hardware checks – Intelligent Substation Device (ISD)	8
3.4	Other, non-requirement specific tests.....	27
3.5	LV-CAP™ system checks	28
3.5.1	Control server	28
3.5.2	LV-CAP™ Platform	31
3.5.3	Monitoring capability.....	32
3.6	Post-FATs meeting.....	41
3.7	Sign-off and acceptance	42
4	Factory Acceptance Tests – Part 2	43
4.1	Attendees	43
4.1.1	Western Power Distribution (WPD).....	43
4.1.2	EA Technology.....	43
4.1.3	Lucy Electric	43
4.2	Setup Details	43
4.2.1	Login details	43
4.3	LV-CAP™ system checks	44
4.3.1	Monitoring capability.....	44
4.3.2	Lucy Electric ‘cloud based’ data server.....	45

4.3.3	ALVIN Reclose™ connectivity	48
4.4	Actions from the FATs Part 2.....	53
4.5	Sign-off and acceptance	54
5	Appendices.....	55
Appendix A.	Factory Acceptance Test setup	60
Appendix B.	Data sheet – ISD Enclosure	61
Appendix C.	Data sheet – Enclosure glands	62
Appendix D.	Data sheet – Isolation switch	63
Appendix E.	Data sheet – LV-CAP™ PC platform.....	64
Appendix F.	Container Manager Manual – Document reference 2358.....	65
Appendix G.	Load profile test	71
Appendix H.	Data Reading Test	75
Appendix I.	ALVIN Control Test	77

Table of figures

Figure 1: FAT Setup	60
---------------------------	----

Table of tables

Table 1 - Image JSON object for the Container Managers Config	66
---	----

1 Introduction

1.1 Purpose

The testing of the OpenLV solution covers three distinct areas.

- **Factory Acceptance Tests** to verify the equipment meets the requirements detailed in the Requirements Specification.
- **Site Acceptance Tests** to verify the solution meets the requirements in realistic, non-laboratory / controlled environment conditions.
- **Cyber-security testing** to evaluate the cyber-security capabilities of the LV-CAP™ platform; these tests will be undertaken by a specialist provider.

This document details the Factory Acceptance Tests (FATs) for the overall OpenLV solution.

1.2 Scope

The tests in this document are based upon the functionality documented in the OpenLV Requirements Specification. Factory Acceptance Testing (FAT) will be performed using this specification.

1.3 Environment

A representative setup of the OpenLV solution was established in the testing laboratories at EA Technology's Capenhurst offices.

This setup comprises two OpenLV solutions, connected in an equivalent manner to the planned trial deployments locations under Method 1 for the Project.

1.4 Test Data & Verification

Each test case lists the following:

- The objectives of the overall test;
- The initial conditions;
- A list of numbered actions with their corresponding expected results; and
- A test results record for the overall test including the result, date, name of the tester and name of the witness. White space is left after each test to allow for the recording of comments, issues, etc.

2 Factory Acceptance Tests (FATs)

The FATs are separated into discrete areas, those that test the OpenLV solution (the LV-CAP™ platform and associated hardware) and those that test the applications to be deployed for the provision of trial functionality.

The tests outlined below have been scheduled to minimise repeated tasks and wherever possible, to enable a single action, or sequence of actions to demonstrate that multiple requirements are met where appropriate to do so.

Each test clearly details which requirement(s) it is testing, and the system area(s) it applies to.

It is not intended to undertake tests relating to the cyber-security requirements at the same time as the hardware and functionality tests. Due to the nature of cyber-security testing, particularly penetration testing, specifically the duration required for effective evaluation, and the potential conflict of simultaneous tests being undertaken, these will be appraised separately by NCC Group, the OpenLV Project's cyber-security specialist.

Testing was separated into two sessions due to the availability of some testing elements. Not all tests undertaken in Part 1 were repeated in Part 2 as there was no requirement to repeat tests, given that nothing had changed within that part of the solution in the interim period.

Where further work on the solution between Part 1 and Part 2 FATs had the potential to affect the results, individual FATs were repeated for assurance purposes.

3 Factory Acceptance Tests – Part 1

The Part 1 FATs were conducted on August 16th, 2017.

3.1 Attendees

3.1.1 Western Power Distribution (WPD)

- Mark Dale (MD)

3.1.2 EA Technology

- Richard Potter (RP)
- Richard Ash (RA)
- Tim Butler (TB)

3.1.3 Nortech Management Ltd.

- Julian Brown (JB)
- Lee Fitzpatrick (LP)

3.1.4 Lucy Electric

- Simon Andrews (SA)
- Stuart Brady (SB)
- Jordan Griffiths (JG)

3.2 Setup Details

3.2.1 Login details

Direct access to the LV-CAP™ test platform requires a username and password. These are:

- Username: installer
- Password: LvCAP6wpd

In both cases, these are case sensitive.

To undertake the tests, the following additional computers, beyond the LV-CAP™ platform, will be required:

- 1x laptop to provide direct access to and control the router modems within the enclosure.
- 1x laptop to provide access to the iHost control server.
- 1x laptop containing development tools for the LV-CAP™ platform.

3.3 Hardware checks – Intelligent Substation Device (ISD)

This section covers tests relating to the physical architecture elements of the trial system.

Test	1	
Requirement No.	Must (M:) 059	Should (S:)
Objective	To confirm the iHost server is installed behind a physical firewall restricting unauthorised access as far as is reasonably practicable.	
System Area	ISD	iHost Control Server
	Lucy Data Server	LV-CAP™ Platform
	LV Monitoring	Thermal Monitoring
	LV Meshing	Load Profile Predictor
	CSV Data Recorder	Loadsense
	Dynamic Thermal Rating	Management Communications
	Data Upload Communications	Peer-to-peer Communications
	Cyber-Security ✓	Overall System
Initial condition	<p>The iHost server is physically located within a secure part of EA Technology’s Capenhurst offices.</p> <p>The server rack is locked at all times with only select individuals having keys to access the server directly.</p>	
Action(s)	<p>1. Visually verify that a firewall is installed within the iHost server rack and has been connected to the primary and backup servers.</p>	
Expected Result	Firewall confirmed to be present and operational.	
Pass / Fail	Pass	
Comments	<p>No comments or queries.</p> <p>Explanation provided of iHost server and backup setup along with the firewall arrangement and purpose behind it.</p>	

Test	2	
Requirement No.	Must (M:) 011, 089	Should (S:)
Objective	To confirm the enclosure can be mounted through multiple means; direct mounting; magnetic mounting; securing to floor.	
System Area	ISD	iHost Control Server ✓
	Lucy Data Server	LV-CAP™ Platform
	LV Monitoring	Thermal Monitoring
	LV Meshing	Load Profile Predictor
	CSV Data Recorder	Loadsense
	Dynamic Thermal Rating	Management Communications
	Data Upload Communications	Peer-to-peer Communications
	Cyber-Security	Overall System
Initial condition	Enclosure on test-bench for inspection of multiple mounting arrangements.	
Action(s)	<ol style="list-style-type: none"> 1. Verify enclosure has capability for multiple mounting arrangements and confirm that brackets have been designed and verified as suitable where necessary. 2. Relocate enclosure to switchgear / transformer equipment to demonstrate magnetic mounting arrangement. 	
Expected Result	<p>To be provided with evidence of the wall mount suitability.</p> <p>For magnetic mounting, a frame will be necessary to support some of the weight of the enclosure.</p> <p>Floor mounting will utilise the same mounting points as wall mounting.</p>	
Pass / Fail	Pass	
Comments	No comments or queries.	

Test	3	
Requirement No.	Must (M:) 006	Should (S:)
Objective	To confirm the enclosure is suitably IP rated for the potential environments into which the trial equipment will be installed.	
System Area	ISD	iHost Control Server ✓
	Lucy Data Server	LV-CAP™ Platform
	LV Monitoring	Thermal Monitoring
	LV Meshing	Load Profile Predictor
	CSV Data Recorder	Loadsense
	Dynamic Thermal Rating	Management Communications
	Data Upload Communications	Peer-to-peer Communications
	Cyber-Security	Overall System
Initial condition	Not applicable – no change expected.	
Action(s)	<ol style="list-style-type: none"> Verify IP rating of enclosure and that work undertaken to install equipment, modules and glands has not affected the rating. <ul style="list-style-type: none"> Data sheet for the enclosure is located in the appendices, Appendix B. Data sheet for the enclosure gland fitting is located in Appendix C. Data sheet for the isolation switch is located in Appendix D. 	
Expected Result	<p>Datasheet confirms enclosure is of a suitable IP rating (xxx).</p> <p>Installation of equipment, modules, and glands to have been undertaken in accordance with manufacturers' instructions.</p>	
Pass / Fail	Pass	
Comments	Datasheets attached to appendices of this test document.	

Test	4	
Requirement No.	Must (M:) 009	Should (S:)
Objective	To confirm the enclosure is non-conductive to avoid potential earthing issues.	
System Area	ISD	iHost Control Server ✓
	Lucy Data Server	LV-CAP™ Platform
	LV Monitoring	Thermal Monitoring
	LV Meshing	Load Profile Predictor
	CSV Data Recorder	Loadsense
	Dynamic Thermal Rating	Management Communications
	Data Upload Communications	Peer-to-peer Communications
	Cyber-Security	Overall System
Initial condition	Not applicable – no change expected.	
Action(s)	1. Verify the enclosure is non-conductive, either through direct demonstration or checking of the product's datasheet.	
Expected Result	Datasheet confirms enclosure is manufactured of a non-conductive plastic.	
Pass / Fail	Pass	
Comments	No comment or queries.	

Test	5	
Requirement No.	Must (M:) 016, 018, 087, 088	Should (S:)
Objective	To confirm the Peer-to-Peer Communications Application enables the transfer of selected data sets between two appropriately configured LV-CAP™ platforms and hence confirm that data can be transferred directly between platforms without the need for a centralised data platform.	
System Area	ISD	iHost Control Server
	Lucy Data Server	LV-CAP™ Platform
	LV Monitoring	Thermal Monitoring
	LV Meshing	Load Profile Predictor
	CSV Data Recorder	Loadsense
	Dynamic Thermal Rating	Management Communications
	Data Upload Communications	Peer-to-peer Communications ✓
	Cyber-Security	Overall System
Initial condition	Enclosures and ancillary equipment on test-bench for inspection. OpenLV hardware energised, running in LV-CAP™ configuration. User with appropriate privileges logged into the controlling iHost server. User with appropriate privileges logged into the Data Centre server.	
Action(s)	<ol style="list-style-type: none"> 1. Ensure the Peer-to-Peer Application is installed on two LV-CAP™ enabled devices / enclosures. 2. Utilise the iHost Control Server to verify the respective applications are configured appropriately to communicate with each other. 3. Ensure the Peer-to-Peer application is active on each platform and set to transfer the 1-minute monitored data between the platforms. 	
Expected Result	1-minute data for both platforms will be verified as present on both platforms.	
Pass / Fail	Pass	
Comments	Verified, as pulling the temperature (transformer) data from the primary LV-CAP™ platform (OpenLV-6) to the secondary LV-CAP™ platform (OpenLV-5) at one-minute intervals.	

Test	6	
Requirement No.	Must (M:) 034	Should (S:)
Objective	To confirm the ALVIN Reclose™ devices are electrically isolated from the ISD enclosure and contents.	
System Area	ISD ✓	iHost Control Server
	Lucy Data Server	LV-CAP™ Platform
	LV Monitoring	Thermal Monitoring
	LV Meshing	Load Profile Predictor
	CSV Data Recorder	Loadsense
	Dynamic Thermal Rating	Management Communications
	Data Upload Communications	Peer-to-peer Communications
	Cyber-Security	Overall System
Initial condition	Enclosures and ancillary equipment on test-bench for inspection. OpenLV hardware energised, running in LV-CAP™ configuration.	
Action(s)	<ol style="list-style-type: none"> 1. Demonstrate the design for connecting the ALVIN Reclose™ devices to the OpenLV ISD. 2. Verify that connection methodology for ALVIN Reclose™ communication link cable within the enclosure provides suitable isolation properties. 	
Expected Result	<p>The connection point for installation of an ALVIN Reclose™ communication cable within the enclosure is suitably isolated.</p> <p>Verified that the data cable connections within the ISD, provide suitable electrical isolation properties.</p>	
Pass / Fail	Pass	
Comments	<p>Brief conversation held around the potential for safe operation and isolation of ALVIN Reclose™ devices in fault conditions and manual network re-arrangements.</p> <p>No issues with the planned approach.</p> <p>Reference Test 8.</p>	

Test	7	
Requirement No.	Must (M:) 003	Should (S:)
Objective	To confirm presence of a 3G / 4G modem / router within the OpenLV solution, connected to the PC unit and energised appropriately.	
System Area	ISD	iHost Control Server ✓
	Lucy Data Server	LV-CAP™ Platform
	LV Monitoring	Thermal Monitoring
	LV Meshing	Load Profile Predictor
	CSV Data Recorder	Loadsense
	Dynamic Thermal Rating	Management Communications
	Data Upload Communications	Peer-to-peer Communications
	Cyber-Security	Overall System
Initial condition	Not applicable – no change expected.	
Action(s)	1. Visual check and verification of the module.	
Expected Result	Visual confirmation of the presence of a 3G / 4G modem / router.	
Pass / Fail	Pass	
Comments	No comments.	

Test	8	
Requirement No.	Must (M:) 008	Should (S:)
Objective	To confirm the demonstrated isolation capability of the ALVIN Reclose™ devices can be 'locked on' in a safe state, such that engineers can be confident that the system will not operate autonomously until the lock is removed.	
System Area	ISD	iHost Control Server ✓
	Lucy Data Server	LV-CAP™ Platform
	LV Monitoring	Thermal Monitoring
	LV Meshing	Load Profile Predictor
	CSV Data Recorder	Loadsense
	Dynamic Thermal Rating	Management Communications
	Data Upload Communications	Peer-to-peer Communications
	Cyber-Security	Overall System
Initial condition	Enclosures and ancillary equipment on test-bench for inspection. OpenLV hardware energised, running in LV-CAP™ configuration.	
Action(s)	1. Verify connections for ALVIN Reclose™ devices are routed through the isolation switch and that it is possible for this switch to be locked in the off position.	
Expected Result	Communication link can be deactivated without requiring access to the interior of the ISD enclosure and this cannot be overridden unintentionally.	
Pass / Fail	Pass	
Comments	Brief conversation held around the potential for safe operation and isolation of ALVIN Reclose™ devices in fault conditions and manual network re-arrangements. No issues with the planned approach. Reference Test 6.	

Test	9	
Requirement No.	Must (M:) 005, 091	Should (S:)
Objective	To confirm the enclosure can be physically secured from unauthorised access.	
System Area	ISD	✓ iHost Control Server
	Lucy Data Server	LV-CAP™ Platform
	LV Monitoring	Thermal Monitoring
	LV Meshing	Load Profile Predictor
	CSV Data Recorder	Loadsense
	Dynamic Thermal Rating	Management Communications
	Data Upload Communications	Peer-to-peer Communications
	Cyber-Security	Overall System
Initial condition	Closed, locked.	
Action(s)	1. Verify that enclosure can be 'locked' with a standard T-bar key and can be padlocked.	
Expected Result	Unable to open enclosure without T-bar key and key to alternative means of securing the enclosure if applied.	
Pass / Fail	Pass	
Comments	<p>No comment or queries.</p> <p>Reference Test 14 for details of agreed padlock key ownership to restrict access to enclosure interior.</p>	

Test	10	
Requirement No.	Must (M:) 001	Should (S:)
Objective	To confirm that the computational hardware is based on PC processing architecture and is within an industrialised PC unit.	
System Area	ISD ✓	iHost Control Server
	Lucy Data Server	LV-CAP™ Platform
	LV Monitoring	Thermal Monitoring
	LV Meshing	Load Profile Predictor
	CSV Data Recorder	Loadsense
	Dynamic Thermal Rating	Management Communications
	Data Upload Communications	Peer-to-peer Communications
	Cyber-Security	Overall System
Initial condition	Not applicable – no change expected.	
Action(s)	<ol style="list-style-type: none"> 1. Visual check and verification of the platform. 2. Confirm on datasheet (Appendices, section 0), that the processing platform is appropriate architecture. 	
Expected Result	Visual confirmation of the presence of an Advantech UNO_2484G_DS platform.	
Pass / Fail	Pass	
Comments	No comment or queries	

Test	11	
Requirement No.	Must (M:) 013, 020	Should (S:)
Objective	To confirm the LV-CAP™ platform is installed and running successfully on the OpenLV industrial PC, and is running the applications deployed to the platform.	
System Area	ISD	iHost Control Server
	Lucy Data Server	LV-CAP™ Platform ✓
	LV Monitoring	Thermal Monitoring
	LV Meshing	Load Profile Predictor
	CSV Data Recorder	Loadsense
	Dynamic Thermal Rating	Management Communications
	Data Upload Communications	Peer-to-peer Communications
	Cyber-Security	Overall System
Initial condition	OpenLV hardware energised, running in LV-CAP™ configuration.	
Action(s)	<ol style="list-style-type: none"> Verify that the LV-CAP™ platform is running on the hardware. Run the command docker ps	
Expected Result	Demonstration that LV-CAP™ is operational: <ol style="list-style-type: none"> nortech/commscontainer is running lvcapcore/marketplace is running lvcapcore/datastorage is running 	
Pass / Fail	Pass	
Comments	No comment or queries	

Test	12	
Requirement No.	Must (M:) 002	Should (S:)
Objective	To confirm that the computation hardware is capable of running the LV-CAP™ platform, the application containers necessary for the OpenLV Project and those additional applications to be developed for Methods 2 & 3.	
System Area	ISD	✓ iHost Control Server
	Lucy Data Server	LV-CAP™ Platform
	LV Monitoring	Thermal Monitoring
	LV Meshing	Load Profile Predictor
	CSV Data Recorder	Loadsense
	Dynamic Thermal Rating	Management Communications
	Data Upload Communications	Peer-to-peer Communications
	Cyber-Security	Overall System
Initial condition	OpenLV hardware energised, running in LV-CAP™ configuration.	
Action(s)	<ol style="list-style-type: none"> As the software for methods 2 and 3 have not yet been developed, determine the level of processor and memory usage for running the current applications and determine that remaining, unused capability is sufficient for additional applications. 	
Expected Result	The majority of CPU and RAM capability to be unutilised during standard operation.	
Pass / Fail	Pass	
Comments	<p>Task manager of the platform shows:</p> <p>Overall CPU utilisation at c1%.</p> <p>Overall RAM usage at c1.5Gb of 8GB.</p> <p>Most of this is 'allocated'; in live use is less than 200mb.</p>	

Test	13	
Requirement No.	Must (M:) 004	Should (S:)
Objective	To confirm that the internal storage capability of the OpenLV solution is sufficient to store all data capture by the sensors and generated by application containers.	
System Area	ISD	iHost Control Server
	Lucy Data Server	LV-CAP™ Platform
	LV Monitoring	Thermal Monitoring
	LV Meshing	Load Profile Predictor
	CSV Data Recorder	Loadsense
	Dynamic Thermal Rating	Management Communications
	Data Upload Communications	Peer-to-peer Communications
	Cyber-Security	Overall System
Initial condition	<p>Some storage will be utilised already due to installation of the Linux OS and LV-CAP™ platform and applications.</p> <p>OS Partition is <15GB.</p> <p>Remainder of the drive (c440GB) is allocated to data storage.</p> <p>It is expected that for the LV-CAP™ platform to be deployed under Method 1 at the start of the project deployment phase, (i.e. no applications from community groups or third-party companies), no more than 200 GB of the HDD's 512GB capacity will be utilised.</p>	
Action(s)	<ol style="list-style-type: none"> Check the available capacity on the HDD and verify that there is sufficient capacity for all data capable of being recorded over the 18-month period of the project trials. <ul style="list-style-type: none"> On the command line, enter the following command df -h <Enter> Verify that there remains a reasonable margin of additional capacity (in excess of 250GB) in the /home/ file system to allow for data from community and third-party applications. 	
Expected Result	<ol style="list-style-type: none"> The internal HDD is partitioned into an OS drive and a database drive. The OS drive is configured to a capacity of c15GB; this will not change and allows for sufficient expansion of the OS if required as part of future updates. The remaining capacity of the HDD (c440 GB) is allocated to data storage. High usage case data requirement estimates for individual platforms are c170GB for the duration of the project under Method 1. <p>A minimum of 250 GB of available capacity on the LV-CAP™ platform's HDD is desirable.</p> <p>In excess of 400GB of space expected.</p>	
Pass / Fail	Pass	

Test	13
Comments	<p>Following initial soak tests at EA Technology and the initial deployment, data usage will be evaluated and checked against forecasts to confirm excessive data isn't being generated by the system.</p> <p>OS drive has 11GB capacity with 3GB in use.</p> <p>Data drive has 446GB capacity with 1.5GB in use with multiple test runs and repeated data samples.</p>

Test	14	
Requirement No.	Must (M:) 012	Should (S:)
Objective	To confirm the enclosure utilised is suitable for the hardware necessary for the OpenLV Project: industrial PC, modem / router, ancillary connections.	
System Area	ISD	iHost Control Server ✓
	Lucy Data Server	LV-CAP™ Platform
	LV Monitoring	Thermal Monitoring
	LV Meshing	Load Profile Predictor
	CSV Data Recorder	Loadsense
	Dynamic Thermal Rating	Management Communications
	Data Upload Communications	Peer-to-peer Communications
	Cyber-Security	Overall System
Initial condition	Enclosure on test-bench for inspection.	
Action(s)	<ol style="list-style-type: none"> 1. Verify enclosure contains all necessary equipment, with sufficient space for safe working in and around the enclosure if required. 2. Additionally, confirm that all points for potential electrical hazard are protected from accidental touch. 	
Expected Result	Enclosure to contain all required assets and be in a safe configuration, suitable for deployment on the LV network.	
Pass / Fail	Pass	
Comments	<p>MD believes that the enclosure should not be accessible to WPD staff.</p> <p>Agreed that EA Technology shall hold the keys for access to each enclosure.</p> <p>Label on the front will be updated with contact details for key staff within WPD and EA Technology and details of isolation methodology (once agreed with WPD).</p> <p>Need to consider risk of vandalism to the ambient temperature sensor radiation shield.</p>	

Test	15	
Requirement No.	Must (M:) 026, 039, 040, 041, 042 & 043	Should (S:)
Objective	To confirm the CSV Data Recorder Application monitors the message broker and records all data gathered by the sensors and information published by the other applications on the platform in non-volatile memory.	
System Area	ISD	iHost Control Server
	Lucy Data Server	LV-CAP™ Platform ✓
	LV Monitoring	Thermal Monitoring
	LV Meshing ✓	Load Profile Predictor
	CSV Data Recorder ✓	Loadsense
	Dynamic Thermal Rating	Management Communications
	Data Upload Communications	Peer-to-peer Communications
	Cyber-Security	Overall System
Initial condition	Enclosures and ancillary equipment on test-bench for inspection. OpenLV hardware energised, running in LV-CAP™ configuration.	
Action(s)	<ol style="list-style-type: none"> 1. After the system has been running for a period of time (at least 48-hours), and other tests as part of the FATs have been undertaken, verify that the data is available within the platform. 2. Run the next test, then return to stage three. 3. Verify the monitored data previously present in the platform is still avail 	
Expected Result	<p>CSV files pertaining to the 'soak test and FATs' generated and stored within the LV-CAP™ platform.</p> <p>All data is timestamped appropriately, matching the output rate of the originating application.</p> <p>The originating application can be identified for all data within the file.</p> <p>The CSV file is stored in non-volatile memory.</p>	
Pass / Fail	Pass	
Comments	No comment or queries	

Test	16	
Requirement No.	Must (M:) 010, 090	Should (S:)
Objective	To confirm that the LV-CAP™ computational hardware within the ISD can be reset without requiring physical access to the enclosure.	
System Area	ISD ✓	iHost Control Server
	Lucy Data Server	LV-CAP™ Platform
	LV Monitoring	Thermal Monitoring
	LV Meshing	Load Profile Predictor
	CSV Data Recorder	Loadsense
	Dynamic Thermal Rating	Management Communications
	Data Upload Communications	Peer-to-peer Communications
	Cyber-Security	Overall System
Initial condition	Enclosures and ancillary equipment on test-bench for inspection. OpenLV hardware energised, running in LV-CAP™ configuration.	

Action(s)

1. Connect to Wireless Logic SSL VPN (NetExtender) using user ssl_lv
2. Connect SSH session to 4G router using Putty:
 - a. IP: see SIM records (10.x.x.x)
 - b. Port: 8192
 - c. Username: root
3. Forward local port "40006" (e.g.) to "localhost:443"
4. Open a web browser and connect to https://localhost:40006
5. Accept the security error for the self-signed router SSL certificate
6. Log in to web interface with user Admin

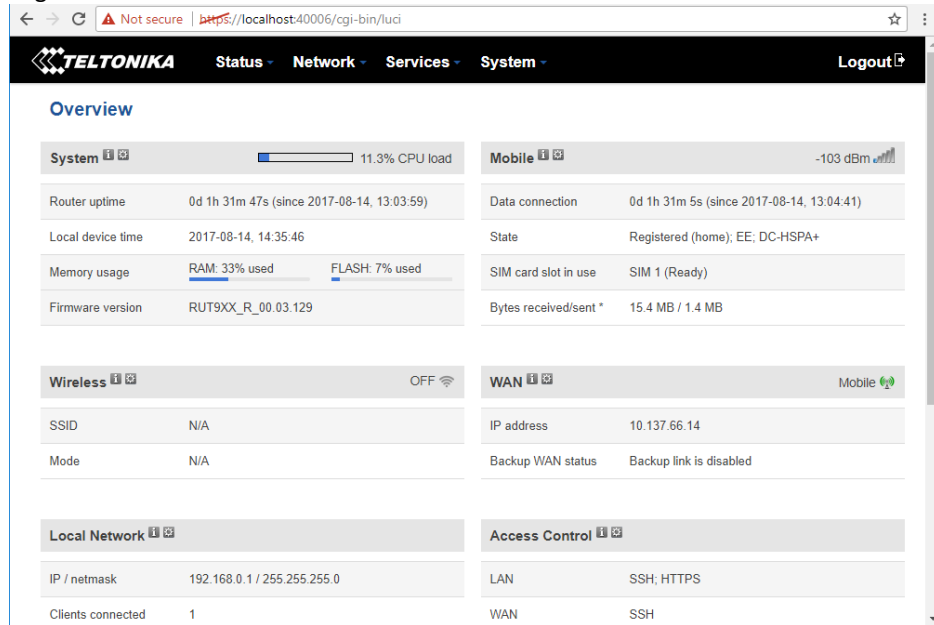

7. Click on Services > Input/Output.

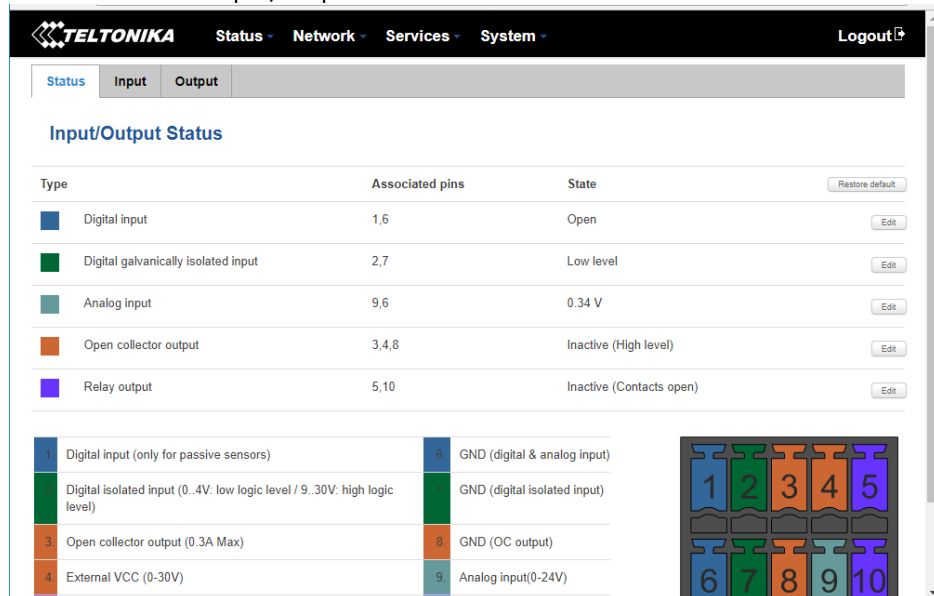

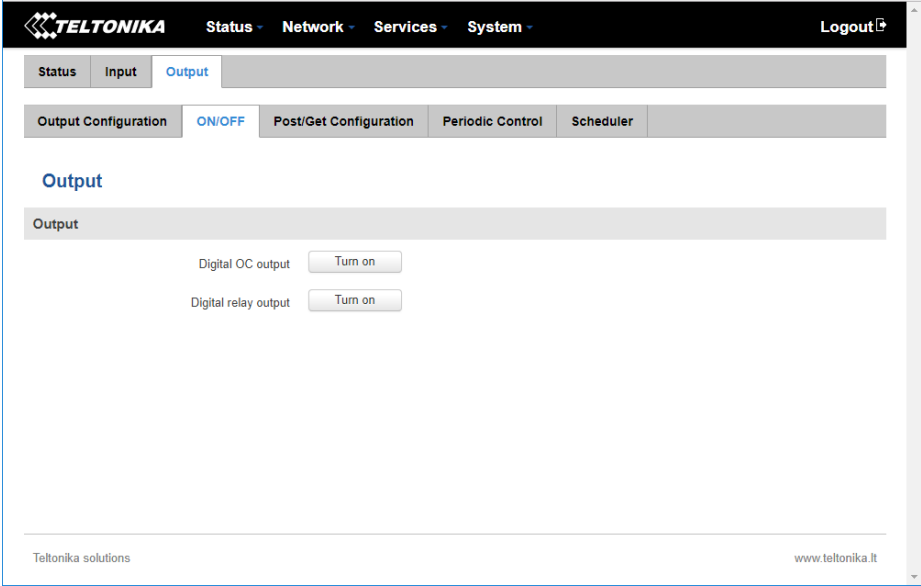
Test	16
	<p>8. Click on the Output sub-tab and then the ON/OFF sub-tab.</p>  <p>9. Click the "Digital OC output" Turn On button. This will remove power from the PC. 10. After the required delay, click the Turn Off button. This will re-apply power to the PC and allow it to start up.</p>
Expected Result	Ruggedised PC will experience a hard shut down, before restarting once power is restored.
Pass / Fail	Pass
Comments	JB noted that it is possible to automate much of the above login process into iHost making accessing the router, if required, much easier.

3.4 Other, non-requirement specific tests

Test	17	
Requirement No.	Must (M:) 092	Should (S:)
Objective	To confirm that cable connection arrangements (power, thermocouple, and communications) are suitable for use on WPD's network	
System Area	ISD	iHost Control Server ✓
	Lucy Data Server	LV-CAP™ Platform
	LV Monitoring	Thermal Monitoring
	LV Meshing	Load Profile Predictor
	CSV Data Recorder	Loadsense
	Dynamic Thermal Rating	Management Communications
	Data Upload Communications	Peer-to-peer Communications
	Cyber-Security	Overall System
Initial condition	Enclosures and ancillary equipment on test-bench for inspection.	
Action(s)	<p>1. Demonstrate the proposed arrangements for providing power to the OpenLV system enclosure.</p> <ul style="list-style-type: none"> • Mains cable – 1.5mm² TRS. Outer diameter 8-9mm. • Ethernet cable. • PVC coated thermocouple cables. 	
Expected Result	Proposed cables confirmed as acceptable for use on WPD's LV network as part of the OpenLV trials.	
Pass / Fail	Pass	
Comments	<p>Fused spur would be preferred for powering the enclosure and equipment rather than a 3-pin socket.</p> <p>It should be planned to not use 3-pin sockets even if available.</p> <p>No issues with the proposed power cables (non-armoured) with the expectation that it (along with GridKey data cable) will be routed within trunking, ducting or similar depending on site-specific requirements and availability.</p> <p>Potential for the use of access cylinder to the transformer oil pocket, in situations where selected sites have suitable transformers.</p> <p>MD to take a thermocouple to verify the maximum suitable length of the thermocouple sensor.</p>	

3.5 LV-CAP™ system checks

This section covers tests relating to the LV-CAP™ platform and associated command and control elements.

3.5.1 Control server

Test	18	
Requirement No.	Must (M:) 051a	Should (S:)
Objective	To confirm that access to the centralised 'command and control system' (the project's iHost server) requires a unique login and password.	
System Area	ISD	iHost Control Server ✓
	Lucy Data Server	LV-CAP™ Platform
	LV Monitoring	Thermal Monitoring
	LV Meshing	Load Profile Predictor
	CSV Data Recorder	Loadsense
	Dynamic Thermal Rating	Management Communications
	Data Upload Communications	Peer-to-peer Communications
	Cyber-Security ✓	Overall System
Initial condition	No user logged into the iHost server, web portal onscreen.	
Action(s)	1. Demonstrate that access to the system is unsuccessful without using the correct username and password combination.	
Expected Result	Correct password combination required before access is granted to the iHost interface.	
Pass / Fail	Pass	
Comments	No comment or queries	

Test	19	
Requirement No.	Must (M:) 054, 055, 056, 061, 062, 063, 064, 074, 075, 076	Should (S:)
Objective	To confirm it is possible to update and remove application containers to any combination of devices.	
System Area	ISD	iHost Control Server ✓
	Lucy Data Server	LV-CAP™ Platform ✓
	LV Monitoring	Thermal Monitoring
	LV Meshing	Load Profile Predictor
	CSV Data Recorder	Loadsense
	Dynamic Thermal Rating	Management Communications ✓
	Data Upload Communications	Peer-to-peer Communications
	Cyber-Security	Overall System
Initial condition	<p>Enclosures and ancillary equipment on test-bench for inspection.</p> <p>OpenLV hardware energised, running in LV-CAP™ configuration.</p> <p>User with appropriate privileges logged into the controlling iHost server.</p> <p>Keyboard and monitor attached to OpenLV system for monitoring, logged in as "installer" user.</p> <p>LV-CAP development tool set available to monitor traffic.</p>	
Action(s)	<ol style="list-style-type: none"> 1. Verify the Modbus Communication Container is running by subscribing to its output topic. Temperature is reported every 10 seconds. Command make sub-tcp 2. Save the Container Manager configuration file from the iHost web interface (we will want it back later). 3. Edit the Container Manager configuration file on iHost and remove the Modus Communication Container section. Save the file. 4. Allow 2 minutes for the configuration file to be downloaded and applied. 5. The temperature messages will stop being reported. 6. Re-upload the original Container Manager configuration file to iHost in the "containers" folder, over-writing the existing file. Edit the file and make a non-change to ensure the timestamp is updated. 7. Allow 2 minutes for the configuration file to be downloaded and applied. 8. The temperature messages will start being reported again. 	
Expected Result	<ol style="list-style-type: none"> 1. Console shows steady stream of readings from the temperature sensors. 2. – 3. – 4. Comms Application downloads updated CM configuration. 5. Console output stops. 6. – 7. Comms Application downloads updated CM configuration. 8. Console shows steady stream of readings from the temperature sensors 	

Pass / Fail	Pass
Comments	No comment or queries

3.5.2 LV-CAP™ Platform

Test	20	
Requirement No.	Must (M:) 053, 077	Should (S:) 008
Objective	<p>To confirm the OpenLV system’s ability to handle a loss-of-power event during a download of an application or configuration updates.</p> <p>To confirm the OpenLV system’s ability to successfully download and deploy an application container to the LV-CAP™ platform.</p>	
System Area	ISD	iHost Control Server ✓
	Lucy Data Server	LV-CAP™ Platform
	LV Monitoring	Thermal Monitoring
	LV Meshing	Load Profile Predictor
	CSV Data Recorder	Loadsense
	Dynamic Thermal Rating	Management Communications ✓
	Data Upload Communications	Peer-to-peer Communications
	Cyber-Security	Overall System ✓
Initial condition	<p>Enclosures and ancillary equipment on test-bench for inspection.</p> <p>OpenLV hardware energised, running in LV-CAP™ configuration.</p> <p>User with appropriate privileges logged into the controlling iHost server.</p>	
Action(s)	<ol style="list-style-type: none"> 1. Upload a newer (copy) of the Modbus TCP sensor application onto iHost, folder containers and overwriting existing file. 2. Edit the modification time entry in the Container Manager configuration file to reflect the modification time of the new Application image. 3. Watch the log of the Nortech Comms application for the start of the application download. “Downloading new container ...” 4. Whilst download is in progress, perform a hard-shutdown of the system through removal of power. 5. After a period of at least 30 seconds re-activate the power and allow the system to restart normally. 	
Expected Result	The system should resume or restart the download once communications are re-established and then apply changes once the download is complete.	
Pass / Fail	Pass	
Comments	System took three attempts to download the file on subsequent restart due to time-out on network signal.	

3.5.3 Monitoring capability

Test	21	
Requirement No.	Must (M:) 014	Should (S:)
Objective	To confirm the OpenLV hardware includes the monitoring equipment to gather the necessary data for project delivery.	
System Area	ISD ✓	iHost Control Server
	Lucy Data Server	LV-CAP™ Platform
	LV Monitoring	Thermal Monitoring
	LV Meshing	Load Profile Predictor
	CSV Data Recorder	Loadsense
	Dynamic Thermal Rating	Management Communications
	Data Upload Communications	Peer-to-peer Communications
	Cyber-Security	Overall System ✓
Initial condition	Enclosure and ancillary equipment on test-bench for inspection.	
Action(s)	1. Verify that ancillary monitoring equipment (GridKey MCU520 and temperature monitoring hardware) is present.	
Expected Result	Appropriate data cables utilised to securely connect each device.	
Pass / Fail	Pass	
Comments	No comment or queries	

Test	22	
Requirement No.	Must (M:) 015	Should (S:)
Objective	To confirm the LV-CAP™ hardware connects to the monitoring hardware: <ul style="list-style-type: none"> MCU520 device; Temperature monitoring probes. 	
System Area	ISD ✓	iHost Control Server
	Lucy Data Server	LV-CAP™ Platform ✓
	LV Monitoring ✓	Thermal Monitoring ✓
	LV Meshing	Load Profile Predictor
	CSV Data Recorder	Loadsense
	Dynamic Thermal Rating	Management Communications
	Data Upload Communications	Peer-to-peer Communications
	Cyber-Security	Overall System
Initial condition	Enclosure and ancillary equipment on test-bench for inspection. OpenLV hardware energised, running in LV-CAP™ configuration.	
Action(s)	<ol style="list-style-type: none"> Verify that the MCU520 is connected to the enclosure and subsequently to the LV-CAP™ platform and providing data into the system. Verify that the temperature monitor is connected to the enclosure and subsequently to the LV-CAP™ platform and providing data into the system. 	
Expected Result	<ol style="list-style-type: none"> MCU520 connected to the LV-CAP™ platform and providing data to the platform. Temperature monitor connected to the LV-CAP™ platform and providing data to the platform. 	
Pass / Fail	Pass	
Comments	No comment or queries	

Test	23	
Requirement No.	Must (M:) 021, 022, 023, 025, 027	Should (S:)
Objective	<p>To confirm the ISD can monitor:</p> <ul style="list-style-type: none"> • Voltage (RMS phase to neutral) for three phases; • RMS current for each phase in each circuit monitored; • Power factor for each phase; • Real and reactive power flow in each phase; • Ambient air temperature (indoor and outdoor); • Transformer top oil temperature (if acceptable to WPD). <p>Also, to confirm this data is recorded by the platform.</p>	
System Area	ISD ✓	iHost Control Server
	Lucy Data Server	LV-CAP™ Platform
	LV Monitoring ✓	Thermal Monitoring ✓
	LV Meshing	Load Profile Predictor
	CSV Data Recorder	Loadsense
	Dynamic Thermal Rating	Management Communications
	Data Upload Communications	Peer-to-peer Communications
	Cyber-Security	Overall System
Initial condition	OpenLV hardware energised, running in LV-CAP™ configuration with monitoring equipment connected.	
Action(s)	<ol style="list-style-type: none"> 1. View the data feed within the platform to demonstrate live feed data is being provided by the sensors. 2. Thermal variation of the temperature probes to enact changes. <ul style="list-style-type: none"> • Use of hot and chilled water to generate temperature swings. 3. Varying the provided current and voltage. 4. Verify the readings generated are time-stamped appropriately. 	
Expected Result	<ol style="list-style-type: none"> 1. Output of sensors scrolling at one-minute intervals. 2. Measured temperature for the affected probe rises and falls significantly in accordance with expectations. 3. Monitored voltage and current increase and decrease in accordance with expectations. 4. Each reading is time-stamped appropriately. 	
Pass / Fail	Pass	

Comments	<p>Readings produced by the GridKey Platform and verified by separate meters.</p> <p>Temperature readings for thermocouples varied through use of hot and cold water.</p> <p>Pre-deployment commissioning to include verification of the impact of phasing on current readings.</p> <p>Commissioning process must include verification of phase angle at point of installation.</p>
-----------------	---

Test	24	
Requirement No.	Must (M:) 024	Should (S:)
Objective	To confirm that the complete system (LV-CAP™ platform and MCU520) can record the monitored values at a constant rate of once every ten (10) seconds for a period of at least one hour.	
System Area	ISD ✓	iHost Control Server
	Lucy Data Server	LV-CAP™ Platform ✓
	LV Monitoring ✓	Thermal Monitoring
	LV Meshing	Load Profile Predictor
	CSV Data Recorder	Loadsense
	Dynamic Thermal Rating	Management Communications
	Data Upload Communications	Peer-to-peer Communications
	Cyber-Security	Overall System
Initial condition	Enclosures and ancillary equipment on test-bench for inspection. OpenLV hardware energised, running in LV-CAP™ configuration.	
Action(s)	1. Demonstrate that readings can be monitored and recorded at an (actual and timestamped) rate of six times per minute (once every ten seconds) and that this can be undertaken for a period of not less than one hour.	
Expected Result	Data being monitored by the OpenLV solution, (voltage & current) is stored within the platform at the same time and timestamped appropriately.	
Pass / Fail	Pass	
Comments	Verified that MCU520 platform is outputting at 10-second intervals and being recorded within the system memory.	

Test	25	
Requirement No.	Must (M:)	Should (S:) 003
Objective	To confirm that the rate of temperature monitoring by the OpenLV solution can be varied from once per minute to once every 10-seconds, 10-second intervals.	
System Area	ISD	iHost Control Server
	Lucy Data Server	LV-CAP™ Platform ✓
	LV Monitoring	Thermal Monitoring ✓
	LV Meshing	Load Profile Predictor
	CSV Data Recorder ✓	Loadsense
	Dynamic Thermal Rating	Management Communications
	Data Upload Communications	Peer-to-peer Communications
	Cyber-Security	Overall System
Initial condition	Enclosures and ancillary equipment on test-bench for inspection. OpenLV hardware energised, running in LV-CAP™ configuration.	
Action(s)	1. Demonstrate that readings can be monitored and recorded at an (actual and timestamped) rate of six times per minute (once every ten seconds) and that this can be undertaken for a period of not less than one hour.	
Expected Result	Data being monitored by the OpenLV solution, (temperature) is stored within the platform at the same time and timestamped appropriately.	
Pass / Fail	Pass	
Comments	No comment or queries	

Test	26	
Requirement No.	Must (M:) 038	Should (S:)
Objective	To confirm the Load Profile Predictor application generates forecast load profiles for the next 24-hour period, at a frequency of once per hour.	
System Area	ISD	iHost Control Server
	Lucy Data Server	LV-CAP™ Platform ✓
	LV Monitoring	Thermal Monitoring
	LV Meshing	Load Profile Predictor ✓
	CSV Data Recorder ✓	Loadsense
	Dynamic Thermal Rating	Management Communications
	Data Upload Communications	Peer-to-peer Communications
	Cyber-Security	Overall System
Initial condition	Enclosures and ancillary equipment on test-bench for inspection. OpenLV hardware energised, running in LV-CAP™ configuration.	
Action(s)	<ol style="list-style-type: none"> 1. Load the system with sufficient data (more than 28-days) of load data. 2. Continue to provide data to replicate the availability of load data for the application. 3. Verify that load profiles have been generated on an hourly basis over the period in question. 	
Expected Result	Load profiles generated on an hourly basis and were published on the message broker within the LV-CAP™ platform for use by other applications and storage in non-volatile memory.	
Pass / Fail	Not tested – data not gathered sufficiently to generate calculated outputs.	
Comments	<p>Not tested – data not gathered sufficiently to output calculate outputs.</p> <p>Test to be repeated in FATs part 2.</p>	

Test	27	
Requirement No.	Must (M:) 060, 071, 072, 073, 078	Should (S:)
Objective	To confirm that data uploaded to the iHost Control Server is stored such that the original source of the data (deployed LV-CAP™ platform) is readily identifiable. Uploaded data should be marked at 'uploaded' to prevent unnecessary data usage.	
System Area	ISD	iHost Control Server ✓
	Lucy Data Server	LV-CAP™ Platform
	LV Monitoring	Thermal Monitoring
	LV Meshing	Load Profile Predictor
	CSV Data Recorder	Loadsense
	Dynamic Thermal Rating	Management Communications ✓
	Data Upload Communications	Peer-to-peer Communications
	Cyber-Security	Overall System
Initial condition	Enclosures and ancillary equipment on test-bench for inspection. OpenLV hardware energised, running in LV-CAP™ configuration. User with appropriate privileges logged into the controlling iHost server.	
Action(s)	<ol style="list-style-type: none"> 1. Verify that data within the iHost system details the LV-CAP™ platform the data originated from. 2. Install SQLite client on the LV-CAP™ platform to enable direct access to the database storing files on the platform. (This is not required for standard BAU operation but is required to undertake this test.) <ul style="list-style-type: none"> • Install SQLite client with the command sudo apt install sqlite3 • Open the DB sudo sqlite /home/CM/Database/ContainerDB.db • SQL Command - File is attached, now read the contents .read ./uploaded_flag_test.txt 3. This will only show data that has been uploaded to the iHost server since the last output. 	
Expected Result	Data is uploaded to the iHost server by the LV-CAP™ platform on a regular basis. This will be available within the iHost server once each periodic upload is complete.	
Pass / Fail	Pass	
Comments	No comment or queries	

Test	28	
Requirement No.	Must (M:)	Should (S:) 007
Objective	To confirm the OpenLV system's ability to withstand multiple power outages in close succession as may occur in the case of an intermittent fault.	
System Area	ISD	✓ iHost Control Server
	Lucy Data Server	LV-CAP™ Platform
	LV Monitoring	Thermal Monitoring
	LV Meshing	Load Profile Predictor
	CSV Data Recorder	Loadsense
	Dynamic Thermal Rating	Management Communications
	Data Upload Communications	Peer-to-peer Communications
	Cyber-Security	Overall System
Initial condition	Enclosures and ancillary equipment on test-bench for inspection. OpenLV hardware energised, running in LV-CAP™ configuration. User with appropriate privileges logged into the controlling iHost server.	
Action(s)	<ol style="list-style-type: none"> 1. Ensure the system is operational and online. 2. Perform a hard shut-down through removal of power from the ISD enclosure. 3. Wait approximately 90 seconds then re-activate the power for 5 – 10 seconds, before de-activating the power again. 4. Wait approximately 90 seconds then re-activate the power for 5 – 10 seconds, before de-activating the power again. 5. Wait approximately 90 seconds then re-activate the power for 5 – 10 seconds, before de-activating the power again. 6. Wait for the system to fully restart and begin normal operation before commencing access via the iHost Control Server. 7. Verify the platform has restarted successfully and has begun monitoring again. 	
Expected Result	System should restart after final sequence and resume normal operation.	
Pass / Fail	Pass	
Comments	No comment or queries	

3.6 Post-FATs meeting.

- 1 RP emphasised, supported by MD, that the SDRC document must be issued to WPD by the end of September 2017.
- 2 LUCY: RP requires that the Lucy Electric Cloud Data Upload Communication Application be completed and having passed all FAT tests for inclusion within the SDRC documentation.
- 3 RP, RA, TB to discuss Method 1: Loadsense & Weathersense applications.
 - a) ACTION: Weathersense: RP to agree commercial terms with University of Manchester or commit to implementing an equivalent application internally.
 - b) ACTION: Loadsense: TB to provide indicative, planned logic to MD.
- 4 ACTION: TB to provide proposed method statements for installation to MD.
- 5 ACTION: MD to provide example labels for use on the enclosures.
- 6 ACTION: MD to test maximum temperature probe length for uses with transformers.
- 7 ACTION: RA to verify all configuration files for each platform pre-issue.
- 8 Agreed that multiple attendees required for a meeting with Mike Gees 'penetration test experts' at some point in last two weeks of October.
 - a) EA Technology: RP, **RA** & TB
 - b) Nortech Management Ltd: JB, **SH**
 - c) Lucy Electric: To be confirmed
- 9 ACTION: RP, RA & TB to agree appropriate cyber-security tests are undertaken prior to equipment deployment.

MD & Andy Hood coming to Capenhurst on September 11th and 12th; ideally want to talk to them about the Loadsense logic if practical to achieve in time available.

3.7 Sign-off and acceptance

It is acknowledged by all those in attendance at the Factory Acceptance Tests (FATs) undertaken on the OpenLV LV-CAP™ Trial system at EA Technology's Capenhurst offices on August 17th, 2017, that the results and comments detailed against each test in this document are a true record of the tests outcome.

The tests were witnessed by representatives of the below companies:

- Western Power Distribution
- EA Technology
- Nortech Management Ltd.
- Lucy Electric

Name	Company & Role	Signature
Mark Dale	Innovation and Low Carbon Networks Engineer Western Power Distribution	
Richard Ash	Senior Consultant EA Technology	
Richard Potter	Principal Consultant EA Technology	
Tim Butler	Senior Consultant EA Technology	
Julian Brown	Managing Director Nortech Management Ltd.	
Simon Andrews	Senior Software Engineer Lucy Electric	

4 Factory Acceptance Tests – Part 2

The Part 2 FATs were conducted on September 21st, 2017.

4.1 Attendees

4.1.1 Western Power Distribution (WPD)

- Mark Dale (MD)

4.1.2 EA Technology

- Richard Potter (RP)
- Richard Ash (RA)
- Tim Butler (TB)
- Stephen Need (SN) / Piotr Przesmycki (PP)

4.1.3 Lucy Electric

- Stuart Brady (SB)

4.2 Setup Details

4.2.1 Login details

Direct access to the LV-CAP™ test platform requires a username and password. These are:

- Username: installer
- Password: LvCAP6wpd

In both cases, these are case sensitive.

To undertake the tests, the following additional computers, beyond the LV-CAP™ platform, will be required:

- 1x laptop to provide direct access to and control the router modems within the enclosure.
- 1x laptop to provide access to the iHost control server.
- 1x laptop containing development tools for the LV-CAP™ platform.

4.3 LV-CAP™ system checks

4.3.1 Monitoring capability

Test 26, scheduled for the Part 1 FATs was unable to be implemented on August 16th due to insufficient data gathered by the platform in advance of the tests, preventing the load profile predictor application from generating forecast profiles. The test is repeated to be undertaken as part of the Part 2 FATs.

Test	29	
Requirement No.	Must (M:) 038	Should (S:)
Objective	To confirm the Load Profile Predictor application generates forecast load profiles for the next 24-hour period, at a frequency of once per hour.	
System Area	ISD	iHost Control Server
	Lucy Data Server	LV-CAP™ Platform ✓
	LV Monitoring	Thermal Monitoring
	LV Meshing	Load Profile Predictor ✓
	CSV Data Recorder ✓	Loadsense
	Dynamic Thermal Rating	Management Communications
	Data Upload Communications	Peer-to-peer Communications
	Cyber-Security	Overall System
Initial condition	Enclosures and ancillary equipment on test-bench for inspection. OpenLV hardware energised, running in LV-CAP™ configuration.	
Action(s)	Follow the process defined in Appendix G - Load profile test.	
Expected Result	Load profiles generated on an hourly basis and were published on the message broker within the LV-CAP™ platform for use by other applications and storage in non-volatile memory.	
Pass / Fail	Pass	
Comments		

4.3.2 Lucy Electric 'cloud based' data server

Test	30	
Requirement No.	Must (M:) 070	Should (S:)
Objective	To confirm the cloud based data server provided by Lucy Electric is a separate system to their business-as-usual operational systems.	
System Area	ISD	iHost Control Server
	Lucy Data Server ✓	LV-CAP™ Platform
	LV Monitoring	Thermal Monitoring
	LV Meshing	Load Profile Predictor
	CSV Data Recorder	Loadsense
	Dynamic Thermal Rating	Management Communications
	Data Upload Communications	Peer-to-peer Communications
	Cyber-Security	Overall System
Initial condition	A representative Open LV remote cloud based data server is up and running. Access is provided to a browser with an appropriate extension to allow for authorisation headers to be specified.	
Action(s)	<ol style="list-style-type: none"> 1. Access the API using "https://test.gridkey.uk/v1" 2. Take note of the returned Keyspaces 3. Note that the URL does not contain a domain reserved for the business-as-usual GridKey Data Centre 	
Expected Result	<p>The list of Keyspaces configured on the Cassandra node will be output. Each customer or project has their data stored in its own unique Keyspace in a Cassandra database. Therefore, as this is a separate system to the GridKey business-as-usual server, the only Keyspaces available should be the one allocated to "OPENLV01".</p> <p>Also, the domain is "test.gridkey.uk" is not the same one allocated to the business-as-usual customer GridKey Data Centre, which is "customer.gridkey.co.uk"</p>	
Pass / Fail	Pass	
Comments		

Test	31	
Requirement No.	Must (M:) 065, 066, 067, 079, 080, 081, 084, 085, 086	Should (S:)
Objective	<p>To confirm that it is possible to upload a subset of the data, and all of the data, on an LV-CAP™ platform to the Lucy Electric GridKey Data Centre and hence confirm the GridKey Data Centre can receive the data provided by Data Upload Applications installed on the disparate LV-CAP™ enabled platforms deployed for the trials.</p> <p>To confirm that data stored within the Lucy Data Centre can be accessed via an API interface or a web-portal.</p> <p>To confirm the Data Upload Application can manage a loss of communications during file upload to the Data Centre Server, and resume the data transfer once communication links are restored.</p> <p>Once successfully uploaded to the Lucy Data Centre, data should be marked as 'uploaded' within the platform by the Management Communications Application and hence will not be automatically uploaded again.</p> <p>It should be possible to demonstrate that data uploaded to the Data Centre Server is stored such that the original source of the data (deployed LV-CAP™ platform) is readily identifiable.</p>	
System Area	ISD	iHost Control Server
	Lucy Data Server ✓	LV-CAP™ Platform
	LV Monitoring	Thermal Monitoring
	LV Meshing	Load Profile Predictor
	CSV Data Recorder	Loadsense
	Dynamic Thermal Rating	Management Communications
	Data Upload Communications ✓	Peer-to-peer Communications
	Cyber-Security	Overall System
Initial condition	<p>Enclosures and ancillary equipment on test-bench for inspection.</p> <p>OpenLV hardware energised, running in LV-CAP™ configuration.</p> <p>User with appropriate privileges logged into the controlling iHost server and route / modem.</p>	
Action(s)	<ol style="list-style-type: none"> 1. Verify the configuration settings for the Lucy GridKey Data Upload Application and identify the data fields marked for upload to the data server. 2. Then select all data stored on the platform and mark it for upload to the server. 3. Check the data centre to confirm the selected data is being uploaded. 4. During the upload process, terminate the mobile connection through a remote reset of the router modem then allow the platform to reconnect automatically. 5. Verify success of data upload. <ol style="list-style-type: none"> a. Access the data server via the API interface and verify the presence of the uploaded data. b. Access the data server via the web portal and verify the presence of the uploaded data. 6. Verify it is possible to determine which RTU uploaded the data. 7. Ensure that subsequent data uploads do not repeat data transmission. 	

Test	31
Expected Result	<p>Once the modem has re-established a connection to the mobile network, the Data Upload application will resume the transfer of both data and application.</p> <p>Identified data fields present within the Lucy Data Centre after a reasonable period of time to allow for data transfer.</p> <p>It should be possible to identify, select and manipulate data uploaded to the server on a basis of individual or multiple specific LV-CAP™ platforms.</p> <p>Access to the uploaded data will be possible via both the API interface and web portal.</p>
Pass / Fail	<p>Pass.</p> <p>All objectives met except the ability to recover from a loss of comms (the original approach was to remove power rather than just comms) as this caused reboot issues.</p>
Comments	<p>Identified a failure of the previously successful Test 16.</p> <p>The test to determine the system ability to handle loss of communications, identified an issue during system recovery from a hard reboot where the operating system layer requests user input for file recovery and restoration on reboot.</p> <p>This did not occur during previous tests where a hard reboot was initiated and the overall system must be capable of self-recovery in the event this happens in the field.</p> <p>EA Technology to undertake evaluation of the root cause and means to ensure the system can successfully restart autonomously in the future.</p> <p>Test was repeated utilising the approach of removing the network connection between the PC and router then restoring the connection. This approach to the test was successful.</p>

4.3.3 ALVIN Reclose™ connectivity

Test	32	
Requirement No.	Must (M:) 017, 028	Should (S:)
Objective	To confirm the LV-CAP™ hardware connects to the ALVIN Reclose™ devices. To confirm that the LV Network Meshing Application enables communications between the LV-CAP™ platform and connected ALVIN Reclose™ devices.	
System Area	ISD	iHost Control Server
	Lucy Data Server	LV-CAP™ Platform
	LV Monitoring	Thermal Monitoring
	LV Meshing ✓	Load Profile Predictor
	CSV Data Recorder	Loadsense
	Dynamic Thermal Rating	Management Communications
	Data Upload Communications	Peer-to-peer Communications
	Cyber-Security	Overall System
Initial condition	Enclosures and ancillary equipment on test-bench for inspection. OpenLV hardware energised, running in LV-CAP™ configuration with ALVIN Reclose™ devices disconnected from the other equipment.	
Action(s)	Follow the process defined in Appendix H - Data Reading Test.	
Expected Result	ALVIN Reclose™ devices successfully connected to the LV-CAP™ platform and providing data to the platform. The LV-CAP™ Platform demonstrates a working connection between the OpenLV solution equipment and the ALVIN Reclose™ devices.	
Pass / Fail	Pass	
Comments		

Test	33	
Requirement No.	Must (M:) 029	Should (S:)
Objective	To confirm that the LV Network Meshing Application enables the transfer of selected sets of data from the ALVIN Reclose™ devices where connected.	
System Area	ISD	iHost Control Server
	Lucy Data Server	LV-CAP™ Platform
	LV Monitoring	Thermal Monitoring
	LV Meshing ✓	Load Profile Predictor
	CSV Data Recorder	Loadsense
	Dynamic Thermal Rating	Management Communications
	Data Upload Communications	Peer-to-peer Communications
	Cyber-Security	Overall System
Initial condition	Enclosures and ancillary equipment on test-bench for inspection. OpenLV hardware energised, running in LV-CAP™ configuration with ALVIN Reclose™ connected.	
Action(s)	Follow the process defined in Appendix H - Data Reading Test. Variable details below.	
	Register Name	Quantity
	MIR_BUS_VOLTAGE_RMS	Busbar voltage
	MIR_CABLE_VOLTAGE_RMS	Cable voltage
	MIR_LINK_CURRENT_RMS	Current through ALVIN
	MIR_OPEN_OPERATIONS	Number of times the circuit breaker has opened
	MIR_CLOSE_OPERATIONS	Number of times the circuit breaker has closed
	MIR_WATCHDOG_FAULTS_DETECTED	Number of times the ALVIN watchdog has operated
	MIR_CHIP_TEMPERATURE	ALVIN CPU temperature
	MIR_REACTIVE_POWER	Reactive power
	MIR_ACTIVE_POWER	Active power
	MIR_UPTIME_HIGH	Uptime counter
	MIR_SWITCH_TEMPERATURE	ALVIN CB temperature
	MHR_SHADOW_FAULT_STATUS	Fault status flags
Expected Result	Data for the variables detailed above is provided to the message broker.	

Test	33
Pass / Fail	Pass`
Comments	

Test	34	
Requirement No.	Must (M:) 030	Should (S:)
Objective	To confirm that the data from the ALVIN Reclose™ devices is capable of being recorded at a frequency of at least once per minute, in line with other data values.	
System Area	ISD	iHost Control Server
	Lucy Data Server	LV-CAP™ Platform
	LV Monitoring	Thermal Monitoring
	LV Meshing ✓	Load Profile Predictor
	CSV Data Recorder	Loadsense
	Dynamic Thermal Rating	Management Communications
	Data Upload Communications	Peer-to-peer Communications
	Cyber-Security	Overall System
Initial condition	Enclosures and ancillary equipment on test-bench for inspection. OpenLV hardware energised, running in LV-CAP™ configuration with ALVIN Reclose™ connected.	
Action(s)	Follow the process defined in Appendix H - Data Reading Test	
Expected Result	Variables provided by the LV Network Meshing Application are stored within the platform at the same time and timestamped appropriately.	
Pass / Fail	Pass	
Comments		

Test	35	
Requirement No.	Must (M:) 007, 031, 032, 033, 036 & 037	Should (S:)
Objective	<p>To confirm that the LV-CAP™ platform can cause the ALVIN Reclose™ relay to open and close as required.</p> <p>To confirm the OpenLV system's ability to autonomously control connected ALVIN Reclose™ devices can be disabled.</p>	
System Area	ISD	iHost Control Server
	Lucy Data Server	LV-CAP™ Platform
	LV Monitoring	Thermal Monitoring
	LV Meshing ✓	Load Profile Predictor
	CSV Data Recorder	Loadsense
	Dynamic Thermal Rating	Management Communications
	Data Upload Communications	Peer-to-peer Communications
	Cyber-Security	Overall System
Initial condition	<p>Connect an LV-CAP™ platform enclosure to the ALVIN Reclose™ test rig and energise the system.</p> <p>OpenLV hardware energised, running in LV-CAP™ configuration with ALVIN Reclose™ connected and circuit breakers in 'open' configuration.</p>	
Action(s)	Follow the process defined in Appendix I - ALVIN Control Test.	
Expected Result	<p>That:</p> <ol style="list-style-type: none"> 1. The light bulb within the ALVIN test rig will go out as power is removed from the circuit. 2. The circuit will be re-energised, demonstrated by the light bulb being turned on again. 	
Pass / Fail	Pass	
Comments		

4.4 Actions from the FATs Part 2





1. EA Technology to identify the root causes and fixes to the additional errors identified under Teste 31.

4.5 Sign-off and acceptance

It is acknowledged by all those in attendance at the Factory Acceptance Tests (FATs) undertaken on the OpenLV LV-CAP™ Trial system at EA Technology’s Capenhurst offices on September 21st, 2017, that the results and comments detailed against each test in this document are a true record of the tests outcome.

The tests were witnessed by representatives of the below companies:

- Western Power Distribution
- EA Technology
- Lucy Electric

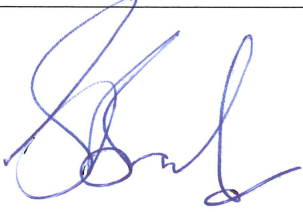
Name	Company & Role	Signature
Mark Dale	Innovation and Low Carbon Networks Engineer Western Power Distribution	
Richard Ash	Senior Consultant EA Technology	
Richard Potter	Principal Consultant EA Technology	
Tim Butler	Senior Consultant EA Technology	
Stuart Brady	Principal Software Engineer Lucy Electric	

5 Appendices

The appendices to this document are:

- Appendix A - Factory Acceptance Test setup
- Appendix B - Data sheet – ISD Enclosure
- Appendix C - Data sheet – Enclosure glands
- Appendix D - Data sheet – Isolation switch
- Appendix E - Data sheet – LV-CAP™ PC platform
- Appendix F - Container Manager Manual – Document reference 2358
- Appendix G - Load profile test

The aim of the Load Profile configuration is to produce a predicted half hourly load current forecast for the next 24 hours. The method adopted for each half hour is to calculate the RMS load during the same half hour on the same day of the week in the previous four weeks. Thus the forecast for 00:00 to 00:30 on day twenty-nine is calculated as the RMS of the load currents between 00:00 and 00:30 on days one, eight, fifteen, twenty-two. The calculations are carried out per-phase for each of the three phases.

Inputs

The Application will take its data input by subscribing to MQTT topics

sensor/data/96d6f19b-7022-45f2-b753-cb5012626b4d/gridkey-mcu520/60/feeder/1/l1/current-mean

sensor/data/96d6f19b-7022-45f2-b753-cb5012626b4d/gridkey-mcu520/60/feeder/1/l2/current-mean

sensor/data/96d6f19b-7022-45f2-b753-cb5012626b4d/gridkey-mcu520/60/feeder/1/l3/current-mean

Payloads in Scalar Object Format (as defined in API section 9.1) will be published on these topics every 60 seconds, containing the measured RMS load current in each phase in Amps (API section 4.5). This is the measurement data from the Lucy GridKey Sensor Application

For testing data will be sent on the same topics but in faster than real time. The following data will be sent, the same for each day on each phase:

- L1: Load Curve G, peak current 100A
- L2: Load Curve 33A, peak current 200A
- L3: Constant current of 300A

This data is contained in the 28 day input data file input-28day.csv and the 1 day input data file which follows it input-1day-w5d1.csv.

Procedure for creating the test data set (for reference only, use above files for testing).

1. Open ODF data generator spreadsheet in LibreOffice Calc
2. Adjust settings to set desired curves, peak currents and start date/time (in UTC)
3. Make sure export sheet is selected sheet.
4. File > Save a Copy ...
5. Change Save as type to Text CSV

6. Enter file name and click Save
7. In export dialogue:
 - a. Character set: Western Europe
 - b. Field delimiter: ,
 - c. Text delimiter: "
 - d. Tick Save cell content as shown and untick the others
 - e. Click OK
8. When it warns only the selected sheet was saved, click OK.
9. This produces a 7 day input file, repeat for more days and edit files together, or chop out the required section for shorter files.

To feed the 28 day input into the system at 3600 times real time (one hour per second) use the command

```
./play_csv.py --host marketplace --port 8883 --cafile broker-ca.pem --cert eatl_tlsdevtools.crt --key eatl_tlsdevtools.key --no-store -i input-28day.csv -f 3600
```

To feed the 1 day input into the system at 60 times real time (one minute per second) use the command

```
./play_csv.py --host marketplace --port 8883 --cafile broker-ca.pem --cert eatl_tlsdevtools.crt --key eatl_tlsdevtools.key --no-store -i input-1day-w5d1.csv -f 3600
```

Configuration

Reference: 2662-MANUL-S001-Vxx.yy.zz

For the Load Profiler the following global settings are used:

Debug: true (turn debug output on)

RefreshRate: 2 (This determines how often outputs can be produced. This setting is in real time regardless of the timestamps in input data).

MaxDataWait: 300 (Data will come in much more often than this in testing).

One profile is configured:

ProfileName: PredictedTxLoad (name for output data)

ProfileCircuit: Transformer(what is this for?)

ProfileTimeSlotAlgorithm: SquaredAverage (we want to use the RMS / geometric mean of the load current values to give the correct heating effects in rating calculations).

ProfileLateDataLimitInSeconds: 120 (we will be feeding in 60 second interval data)

ProfileDailyTimeSlots: 48 (to give 30 minute interval slots)

ProfileWindowLengthDays: 28

Inputs:

value: sensor/data/96d6f19b-7022-45f2-b753-cb5012626b4d/gridkey-mcu520/60/feeder/1/l1/current-mean

value: sensor/data/96d6f19b-7022-45f2-b753-cb5012626b4d/gridkey-mcu520/60/feeder/1/l2/current-mean

value: sensor/data/96d6f19b-7022-45f2-b753-cb5012626b4d/gridkey-mcu520/60/feeder/1/l3/current-mean (three inputs for three phases, from the sensors defined above)

Output Settings:

ProfileOutputTopicString: "tx-load/predict/byday/l1/30/30/1440" (name of the sub-topic the data will be published on)

ProfileOutputIntervalMinutes: 30 (output a new profile every 30 minutes)

ProfileOutputPredictionLengthMinutes: 1440 (24 hour prediction)

ProfileOutputSmoothing: RMS (we want to calculate the RMS / geometric mean of the days)

ProfileOutputValues: value: sensor/data/96d6f19b-7022-45f2-b753-cb5012626b4d/gridkey-mcu520/60/feeder/1/l1/current-mean (only one input, from the sensor defined above)

The same arrangement is repeated for l2 and l3.

LV-CAP is configured to run the Load Profiler and CSV logger applications only. The CSV logger is configured to log the sensor topics to a single CSV file

Outputs

The output profiles must be published on the topics:

- algorithm/data/5414c8fd-4924-4d08-a56a-c7e553b40e3e/tx-load/predict/byday/l1/30/30/1440
- algorithm/data/5414c8fd-4924-4d08-a56a-c7e553b40e3e/tx-load/predict/byday/l2/30/30/1440
- algorithm/data/5414c8fd-4924-4d08-a56a-c7e553b40e3e/tx-load/predict/byday/l3/30/30/1440

The Application must publish profiles in the standard LV-CAP time series JSON format to the above MQTT topic. Each profile produced must start at approximately the current time (based upon the time stamps of the incoming data, not the host system clock). Each profile produced will have 48 elements, each of 30 minutes duration.

To convert timestamps into human-readable UTC time use a command line

```
date -u -d '@1503966600' "+%Y/%m/%d %H:%M:%S %Z"
```

Test Steps

1. Start from a clean LV-CAP core system with no data files or load profile data present.
2. Deploy the TLS Development tools, which include the play_csv.py script. Install any necessary python packages to run the script against the LV-CAP core.
3. Deploy and configure the Load Profiler and Data Storage applications onto the system.
4. Use make sub-sensor to monitor sensor data on the system

5. Play the 28-day history file into the system to build up the profile data (this takes ~12 minutes):
`./play_csv.py --host marketplace --port 8883 --cafile broker-ca.pem --cert eatl_tlsdevtools.crt --key eatl_tlsdevtools.key --no-store -i input-28day.csv -f 3600`
6. When the 28-day data set completes, also monitor the algorithm output with `make sub-alg`
7. Continue to play back the 1 day file at slower speed to see the profiles being produced:
`./play_csv.py --host marketplace --port 8883 --cafile broker-ca.pem --cert eatl_tlsdevtools.crt --key eatl_tlsdevtools.key --no-store -i input-1day-w5d1.csv -f 3600`
8. Examine the profiles produced and check as documented below.

Expected Outputs

The 1 day data file we are using for testing contains data for Tue 29 Aug 2017, so we are looking for the outputs from this day to be produced.

The first three outputs will be produced almost immediately, for l1, l2 and l3 respectively.

- Each will have the same TimeStamp values of 1503966600, which is 2017/08/29 00:30:00 UTC, the first profile of the day.
- TimeStampStart will have a value of 1501547400, which is 2017/08/01 00:30:00 UTC, the date and time 28 days earlier when the oldest data used in the profile was collected.
- On the L1 output, the values are for load curve G at 100A peak, which starts with an hour of 100A, then 96.8A for the next hour and then 93A, ending up with a hour of 99.2A
- On the L2 output, the values are for load curve 33A at 200A peak, which starts with 187A for one hour (two profile steps), then 177.4A and 168.2A, ending up at 200A
- On the L3 output, the values are all 300A because the load does not change!

Now move on to the second set of profiles produced.

- Each will have a TimeStamp value of 1503968400, which is 2017/08/29 01:00:00 UTC, half an hour after the previous profiles.
- TimeStampStart has also moved on to 1501549200 (2017/08/01 01:00:00 UTC).
- On L1 output, things have moved up by half a hour, so we get only one step at 100A, two each at 96.8A and 93A. We end with two at 99.2A and then the 100A value wrapped from the start.
- The same on L2, one step at 187A, two each at 177.4A and 168.2A, ending with two at 200A and one at 187A
- On the L3 output, the values are all 300A because the load does not change!

We can keep doing this for as long as you like, but you get the picture!

- Data Reading Test
- Appendix I - ALVIN Control Test

Appendix A. Factory Acceptance Test setup

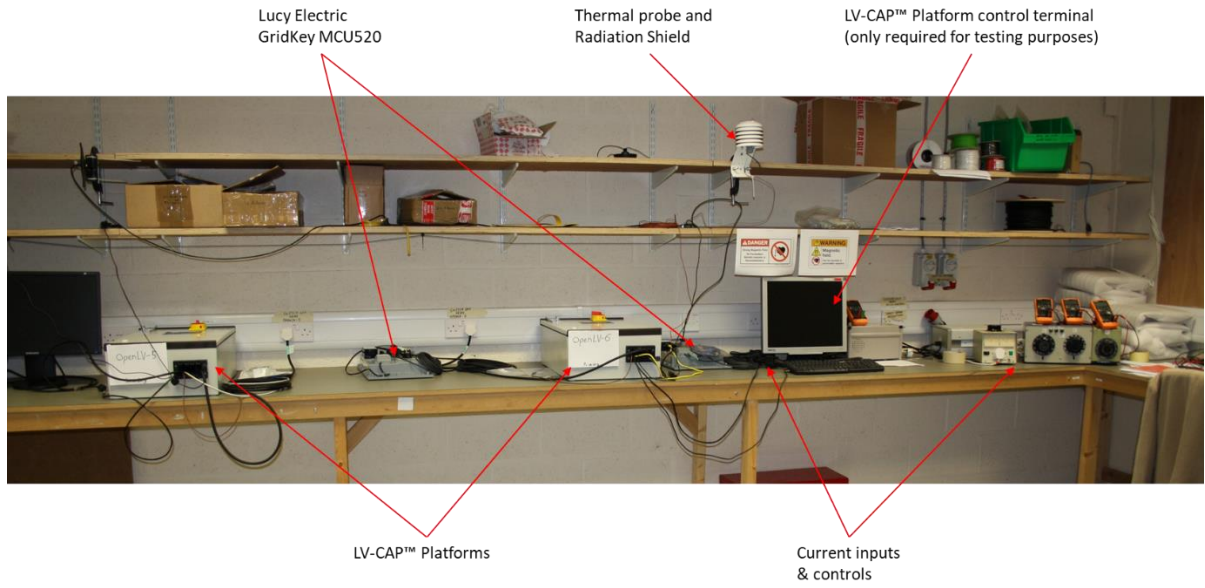

Figure 1: FAT Setup

Appendix B. Data sheet – ISD Enclosure



Enclosure_DataShe
et.pdf

Plastic enclosures KS



System accessories Page 507 **KS for potentially explosive areas** Page 194

Material:

- Enclosure and door: Fibre-glass-reinforced unsaturated polyester
- Door: All-round foamed-in PU seal
- Mounting plate: Sheet steel
- Viewing window: Glazed acrylic, 3.0 mm with all-round rubber cable clamp strip

Surface finish:

- Enclosure and door: Dyed plastic with no after-treatment
- Mounting plate: Zinc-plated

Colour:

- Similar to RAL 7035

Supply includes:

- Enclosure with hinged door, of all-round solid construction, 3 mm double-bit lock
- Mounting plate

- Twin seal on the top and bottom edges of the door as integral rain protection strip
- Press-fitted C sections at the sides for infinitely variable mounting plate depth adjustment

Please note the product-specific scope of supply.

Note:

- Under the influence of long-term UV radiation (sunlight) in conjunction with wind and rain, the surface finish may become visually impaired. This does not affect the protection of the installed electrical components in any way. If the enclosures cannot be protected from UV radiation, we recommend that they should be painted with a PUR paint. Ambient temperature -30°C...+75°C.

Approvals:

- TÜV
- Germanischer Lloyd
- Russian Maritime Register of Shipping
- Lloyds Register of Shipping
- Bureau Veritas

Technical details:

Available on the Internet

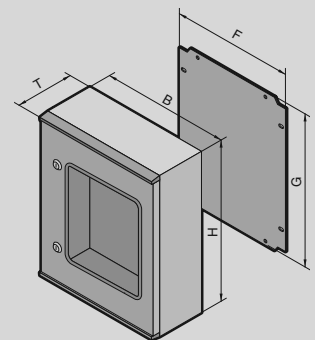

Width (B) mm	Packs of	200	250	300	400	400	400	400	500	Page
Height (H) mm		300	350	400	400	400	600	600	500	
Depth (T) mm		150	150	200	200	200	200	200	300	
Mounting plate width (F) mm		145	195	245	345	345	345	345	417	
Mounting plate height (G) mm		250	300	350	350	350	550	550	450	
Mounting plate thickness mm		2.0	2.0	2.0	2.5	2.5	2.5	2.5	2.5	
Model No.	1 pc(s).	1423.500	1432.500	1434.500	1444.500	1448.500	1446.500	1449.500	1453.500	
Weight kg		3.4	4.3	5.9	7.9	8.0	11.5	11.2	13.5	
Protection category IP to IEC 60 529		IP 66	IP 66	IP 66	IP 66	IP 56	IP 66	IP 56	IP 66	
Protection category NEMA		NEMA 4X	NEMA 4X	NEMA 4X	NEMA 4X	NEMA 12	NEMA 4X	NEMA 12	NEMA 4X	

Product-specific scope of supply

Door(s)		1	1	1	1	1	1	1	1	
Door hinged on the right, may be swapped to the left		■	■	■	■	■	■	■	■	
Removable centre bar, lockable door on right		–	–	–	–	–	–	–	–	
Viewing window		–	–	–	–	■	–	■	–	
Cam lock		1	1	2	2	2	2	2	2	
3-point lock system		–	–	–	–	–	–	–	–	

Accessories

Mounting plate adjustment bracket	4 pc(s).	1481.000	1481.000	1481.000	1481.000	1481.000	1481.000	1481.000	1491.000	594
Threaded inserts M6	20 pc(s).	1482.000	1482.000	1482.000	1482.000	1482.000	1482.000	1482.000	1482.000	625
Pole clamp	1 set(s)	2584.000	2584.000	2584.000	2584.000	2584.000	2584.000	2584.000	2584.000	589
Wall mounting bracket	4 pc(s).	1483.010	1483.010	1483.010	1483.010	1483.010	1483.010	1483.010	1483.010	588
Lock systems		from page	from page	from page	from page	from page	from page	from page	from page	560

Plastic enclosures KS

KS 1423.500, KS 1432.500
with only one cam lock in the centre

Mounting plate

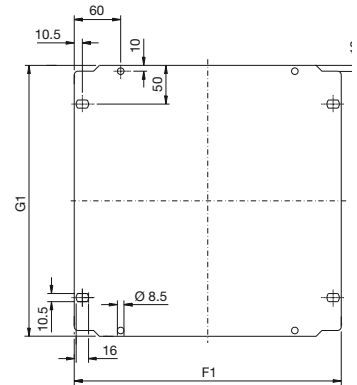
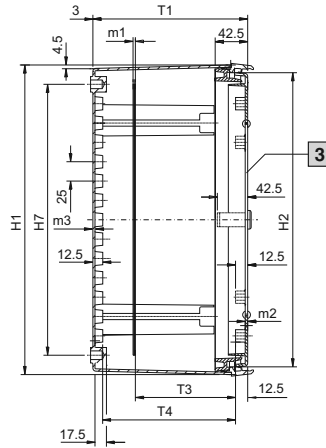
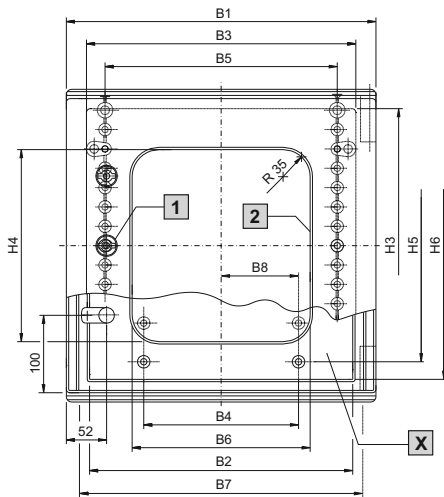

B7 = Separation width for wall mounting hole

H7 = Separation height for wall mounting hole

1 Only for KS 1423.500, KS 1432.500

2 Viewing window only with KS 1448.500, KS 1449.500, KS 1454.500, KS 1467.500



3 Material thickness of viewing window: 3 mm

X Door interior view

Model No. KS	Width dimensions mm							Height dimensions mm							Depth dimensions mm			Material thickness mm			Mounting plate mm		
	B1	B2	B3	B4	B5	B6 ¹⁾	B7	B8	H1	H2	H3	H4 ¹⁾	H5	H6	H7	T1	T3	T4	m1	m2	m3	F1	G1
1423.500	200	140	150	-	100	-	150	25	300	280	256	-	200	245	250	150	80 - 110/117	119	2.0	3.0	3.0	145	250
1432.500	250	190	200	75	150	-	200	50	350	330	306	-	250	295	300	150	80 - 110/117	119	2.0	3.0	3.0	195	300
1434.500	300	240	249	100	200	-	250	50	400	380	355	-	300	345	350	200	80 - 160/167	169	2.0	3.0	3.0	245	350
1444.500/ 1448.500	400	340	348	200	300	230	350	100	400	380	354	250	300	345	350	200	80 - 159/166	168.5	2.5	3.2	3.2	345	350
1446.500/ 1449.500	400	340	348	200	300	230	350	100	600	580	554	450	500	545	550	200	80 - 158/165	168	2.5	3.5	3.5	345	550
1466.500/ 1467.500	600	540	548	400	500	430	550	200	600	580	554	450	500	545	550	200	80 - 158/165	168	2.5	3.5	3.5	545	550
1453.500/ 1454.500	500	440	434	300	400	330	450	150	500	480	454	350	400	445	450	300	80 - 258/265	268	2.5	3.5	3.5	417	450

¹⁾ Only in enclosures with viewing window

Lock cylinder inserts

Version	B	C
		
	With lock no. 3524 E ¹⁾	With lock no. 3524 E ¹⁾
Material	Die-cast zinc	Die-cast zinc
	Model No.	
	2571.000	2525.000

¹⁾ With two keys



Semi-cylinder lock

for compact enclosures AE

For retro-fitting to all single-door enclosures with cam lock.

The cover plate is locked by semi-cylinders with a total length of 40/45 mm (to DIN 18 252). An additional cover protects the cylinder against dirt. The protection category of the enclosure is not impaired. Supplied without semi-cylinder.

Material:

– Die-cast zinc

Version	Model No.
RAL 7035	2534.100
Nickel-plated (matt)	2534.500



Accessories:

– Semi-cylinder, see page 565

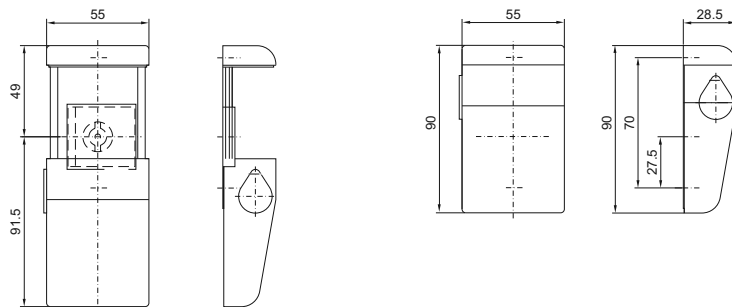

Lock cover

for padlocks or multiple locks

For retrospective mounting on all compact enclosures AE, sheet steel, with cam lock.

Material:

– Die-cast zinc

Surface finish:

– Nickel-plated

Packs of	Model No.
1 pc(s).	2493.000



Appendix C. Data sheet – Enclosure glands



Cube_Gland_DataSheet.pdf

U.I. Lapp GmbH	PRODUCT INFORMATION	
	SKINTOP® CUBE	29.11.2013

Variable range of clamping force
Vibration-safe module fixation
Strain relief
Oil resistance
Simplified servicing due to easy assembling and disassembling



Wide clamping range



Assembly time



Optimum strain relief



Space requirement



Connector with standard housing unit

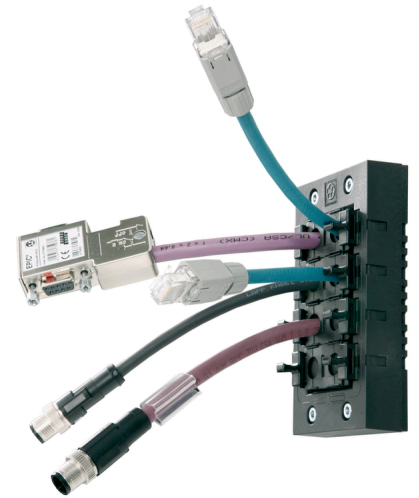

Info

Innovative multi-cable bushing system with variable clamping ranges for high flexibility in assembling.
When disassembling, the frame can remain on the housing and the plug-in module remains securely on the cable.

Application range

For installation of harnessed cables
Used in areas where cables and wires need to be safely inserted into housings
Apparatus and switch cabinet construction
Electronic installations
Automation technology

Design

The SKINTOP® CUBE system consists of the SKINTOP® CUBE FRAME and the clip modules SKINTOP® CUBE MODULE.
For cut-outs for industrial connectors with standard defined boreholes.
For cut-outs for 16-pin industrial connectors (36 x 86 mm)
For cut-outs for 24-pin industrial connectors (36 x 112 mm)

Note

SKINTOP® CUBE MODULE 20x20 BLIND can be used as a blind module and for clamping ranges 1 - 3 mm

Included

SKINTOP® CUBE FRAME including mounting material

Remark

Photographs are not to scale and do not represent detailed images of the respective products.

Product Management	Document: LAPP_PRO101967EN.pdf	1 / 4
--------------------	--------------------------------	-------

U.I. Lapp GmbH	PRODUCT INFORMATION	 LAPP GROUP
	SKINTOP® CUBE	29.11.2013

Technical Data

Approvals:	UL pending
Material:	Frame: glass fibre-reinforced polyamide Frame seal: CR Clip module: special polypropylene Clip module seal: LSE 2
Protection rating:	IP 64 NEMA 12
Temperature range:	-20°C to +80°C

Product Management	Document: LAPP_PRO101967EN.pdf	2 / 4
--------------------	--------------------------------	-------



SKINTOP® CUBE

29.11.2013

Part number	Article designation / size	Clamping range ØF (mm)	Max. number of executions
SKINTOP® CUBE Frame			
52220000	SKINTOP® CUBE FRAME 16		8
52220001	SKINTOP® CUBE FRAME 24		10
SKINTOP® CUBE clip modules			
52220004	SKINTOP® CUBE MODULE 20x20 BLIND	1 - 3	
52220002	SKINTOP® CUBE MODULE 20x20 SMALL	4 - 6	
52220003	SKINTOP® CUBE MODULE 20x20 LARGE	6 - 9	
52220040	SKINTOP® CUBE MODULE 20x20 AS-I BUS		
52220005	SKINTOP® CUBE MODULE 40x40 SMALL	9 - 12	
52220006	SKINTOP® CUBE MODULE 40x40 LARGE	12 - 16	
52220007	SKINTOP® CUBE MODULE 40x40 BLIND		

U.I. Lapp GmbH	PRODUCT INFORMATION	
	SKINTOP® CUBE	29.11.2013

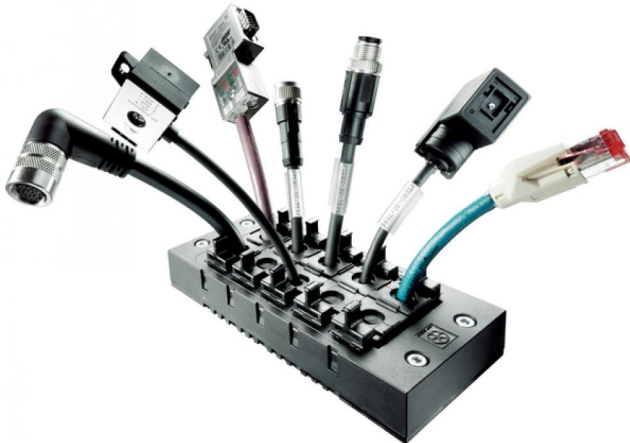
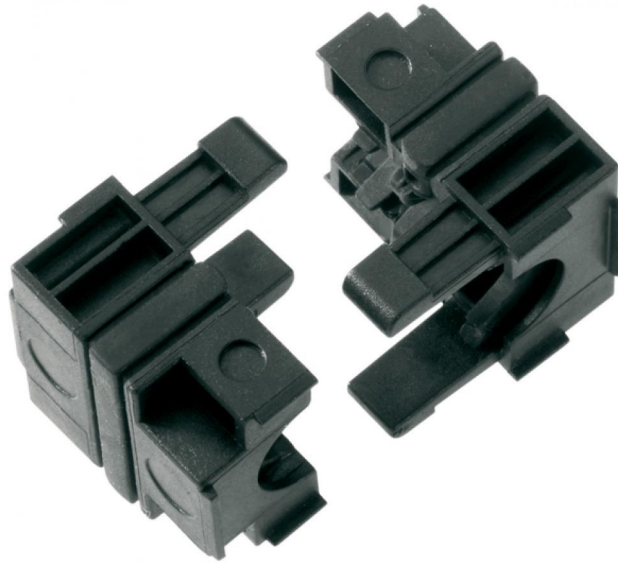

Product Management	Document: LAPP_PRO101967EN.pdf	4 / 4
--------------------	--------------------------------	-------

Appendix D. Data sheet – Isolation switch



Isolator_Switch_DataSheet.pdf



ENGLISH

Datasheet

Stock No: 466-148

RS Pro 3 Pole Front Panel Mount Non-Fused Switch Disconnecter, 25 A, 11 kW, IP65



Product Details

Panel Mount (Padlockable)

RS Pro high quality range of panel mount switch disconnectors for use with low voltage switchgear such as power distribution, load isolation and motor start/stop.

All switch ratings at AC22

RoHS compliant

Maximum panel thickness 3mm

Depth behind panel 102min/117max mm

Dimensions 72(H)x50(W) mm

Actuator dimensions 64x64x32mm

Approvals

UL, CSA



ENGLISH

Specifications:

Number of Poles	3
Maximum Current	25 A
Mounting Type	Front Panel
Power Rating	11 kW
IP Rating	IP65
Accepts Padlocks	Yes
Voltage Rating	750 V
Electrical Phase	3
Switch Rating	6 kV
Length	125mm
Width	100mm
Depth	70mm
Minimum Operating Temperature	-25°C
Maximum Operating Temperature	+40°C
Handle Colour	Red
Terminal Type	Screw

Appendix E. Data sheet – LV-CAP™ PC platform



UNO-2484G_DataSheet.pdf

UNO-2484G

Intel® Core™ i7/i5/i3 Regular-Size Modular Box Platform (MBP) with 4 x GbE, 1 x mPCIe, HDMI, DP

NEW



Features

- Intel® Core™ i7/i5/i3 Processor up to 2.6 GHz with 8GB DDR4 built-in Memory
- 4 x GbE, 4 x USB 3.0, 1 x HDMI, 1 x DP (4K), 4 x RS232/422/485
- Stackable 2nd layer for up to 4 iDoor extension or customize for domain applications
- Compact Fanless Design
- Ruggedized by Zero cable and lockable I/O design
- Optional TPM2.0 for Cyber Security
- Chassis Grounding Protection
- Diverse system I/O and Isolated Digital I/O by iDoor Technology
- Supports Fieldbus Protocol by iDoor Technology
- 3G/GPRS/GPRS/Wi-Fi Communication by iDoor Technology
- Supports 30+ iDOOR combination with four main categories

Introduction

Advantech's new generation UNO-2000 series of Embedded Automation Computers are Fanless with highly ruggedized with embedded operation system. New UNO-2000 series implement Universal, Customized, and Domain idea into modular design concept which provides flexible and time-to-market support in variety of applications. The series also includes iDOOR technology which supports automation feature-extensions such as Multiple I/O Peripheral, Industrial Fieldbus, Smart I/O Communication, and Signal Communication. New UNO-2000 series including pocket, small, and regular-size form-factors with indicated market segments in terms of different kinds of smart factory application categories such as Equipment Connectivity (EC), Process Visualization (PV), Environment Management (EM), and Dispatch Management (DM) solution. New UNO enables smart factory and fulfill all application.

Specifications

General

- Certification** CE, FCC, UL, CCC, BSMI
- Dimensions (W x D x H)** 200 x 140 x 40 (7.8" x 5.6" x 1.6"), Optimized UNO-2484G
200 x 140 x 70 (7.8" x 5.6" x 2.8"), Universal/Domain/Customized UNO-2484G
- Form Factor** Regular Size with stackable design
- Enclosure** Aluminum Housing
- Mounting** Stand, Wall, VESA (Optional), DIN-rail (Optional)
- Weight (Net)** 1.2KG (2.65lb)
- Power Requirement** 10 - 36 V_{DC}
- Power Consumption** 55W (Typical), 85W (Max)
- OS Support** Microsoft® Windows 10, Windows 7, Advantech Linux

System Hardware

- BIOS** AMI EFI64 Mbit
- Watchdog Timer** Programmable 256 levels timer interval, from 1 to 255 sec
- Processor** 6th Gen Intel Core i7-6600U, 2.6GHz 4M Smartcache
6th Gen Intel Core i5-6300U, 2.4GHz 3M Smartcache
6th Gen Intel Core i3-6100U, 2.3GHz 3M Smartcache
Built-in 8GB DDR4 1866/2133 MHz
- Memory** Intel® HD Graphics 520
- Graphics Engine** Intel i219-IT GbE, 802.1Qav, IEEE1588/802.1AS, 802
- Ethernet** Intel i219-IT GbE
- LED Indicators** LEDs for Power, HDD, LAN (Active, Status), RTC
Battery low
- Storage** One mSATA (co-lay mPCIe)
Two drive bay for SATA 2.5" SSD/HDD
CFast by iDOOR Technology (Optional)
- Expansion** 1 x full-size mPCIe slot on first stack
Optional 3 x full-size mPCIe slots on 2nd extension I/O card

I/O Interfaces

- Serial Ports** 4 x RS 232/422/485
- LAN Ports** 4 x RJ45, 10/100/1000 Mbps IEEE 802.3u 1000Base-T Fast Ethernet
- USB Ports** 4 x USB3.0
- Displays** 1 x HDMI supports 1920x1080, 1 X DP supports 4K
- Audio** Line-out
- Power Connector** 1 x 2 Pins, Terminal Block
- Grounding Protection** Chassis Grounding

Environment

- Operating Temperature** -20 ~ 60°C (-4 ~ 140°F) @ 5 ~ 85% RH with 0.7 m/s airflow
- Storage Temperature** -40 ~ 85°C (-40 ~ 185°F)
- Relative Humidity** 10 ~ 95% RH @ 40°C, non-condensing
- Shock Protection** Operating, IEC 60068-2-27, 50G, half sine, 11 ms
- Vibration Protection** Operating, IEC 60068-2-64, 2 Grms, random, 5 ~ 500 Hz, 1hr/axis (mSATA)
- Ingress Protection** IP40

Installation Scenario

DIN-rail Mount Illustration

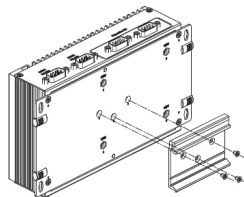

VESA Mount Illustration

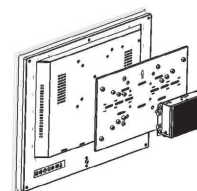

Dimensions

Unit: mm

UNO-2484G Optimized UNO

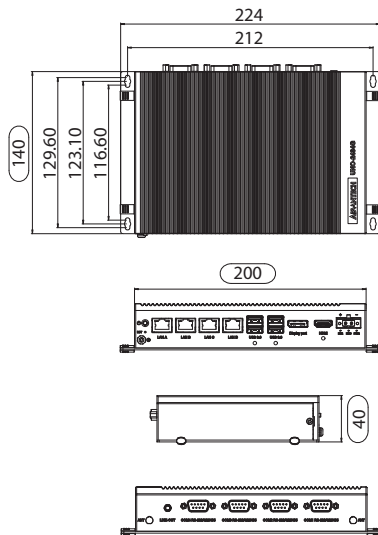

UNO-2484G Universal UNO

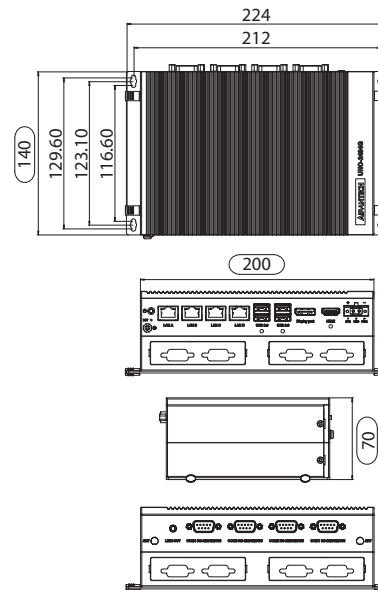

Front I/O View

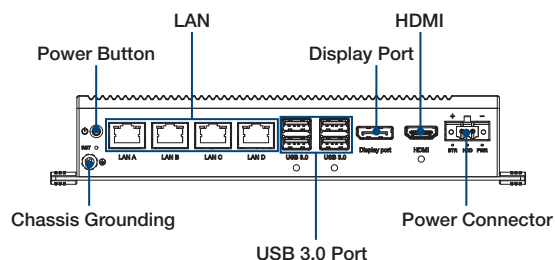

Rear I/O View

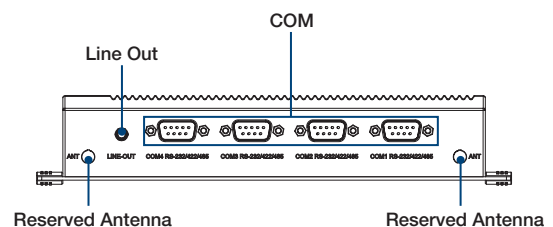

Ordering Information

- **UNO-2484G-6731AE** Intel Core i7-6600U, 2.6GHz, 8G RAM, 4 x GbE LAN, 4 x USB3.0, 4 x COM, 1 x mPCIe
- **UNO-2484G-6531AE** Intel Core i5-6300U, 2.4GHz, 8G RAM, 4 x GbE LAN, 4 x USB3.0, 4 x COM, 1 x mPCIe
- **UNO-2484G-6331AE** Intel Core i3-6100U, 2.3GHz, 8G RAM, 4 x GbE LAN, 4 x USB3.0, 4 x COM, 1 x mPCIe
- **UNO-2484G-6732AE** Universal Intel Core i7-6600U, 2.6GHz, 8G RAM, 4 x GbE LAN, 4 x USB3.0, 4 x COM, 4 x mPCIe
- **UNO-2484G-6532AE** Universal Intel Core i5-6300U, 2.4GHz, 8G RAM, 4 x GbE LAN, 4 x USB3.0, 4 x COM, 4 x mPCIe
- **UNO-2484G-6332AE** Universal Intel Core i3-6100U, 2.3GHz, 8G RAM, 4 x GbE LAN, 4 x USB3.0, 4 x COM, 4 x mPCIe

iDoor Modules

- **PCM-24S2WF-AE** 802.11 a/b/g/n 2T2R w/ Bluetooth4.0, Half-size mPCIe, 2-port SMA
- **PCM-24S23G-AE** 6-band HSPA Cellular Module, GPS, SIM holder, SMAx2
- **PCM-24R2GL-AE** 2-Port Gigabit Ethernet, mPCIe, RJ45
- **PCM-24D2R2-AE** 2-Port Isolated RS-232 mPCIe, DB9
- **PCM-24D4R4-AE** 4-Port Non-Isolated RS-422/485 mPCIe, DB37
- **PCM-24R1TP-AE** 1-Port Gigabit Ethernet, Intel® 82574L, mPCIe, RJ45
- **PCM-27D24DI-AE** 24-Channel Isolated Digital I/O w/ counter mPCIe, DB37

Optional Accessories

- **1702002600** Power Cable US Plug 1.8 M (Industrial Grade)
- **1702002605** Power Cable EU Plug 1.8 M (Industrial Grade)
- **1702031801** Power Cable UK Plug 1.8 M (Industrial Grade)
- **1700000596** Power Cable China/Australia Plug 1.8 M (Industrial Grade)
- **UNO-2000G-VMKAE** UNO-2000 VESA Mount Kit
- **UNO-2000G-DMKAE** UNO-2484G DIN RAIL Kit
- **TBD** Windows 10 Enterprise image for UNO-2484G
- **TBD** WES7P image for UNO-2484G MUI

Appendix F. Container Manager Manual – Document reference 2358

The content in this appendix is extracted from the Container Manager Manual, document reference 2358, on Monday August 14th and will not be kept up-to-date with future updates to that document.

iHost

website: <https://test.nortechonline.net/ihost/>

Login

Request a login from one of the following:

1. Richard Ash
2. James Slater
3. Jake Williams
4. Sion Hughes
5. Ben Cossins

New Image & Config upload

Files needed:

- New Image file to be uploaded (<IID>.tar)
- The New Images config (<IID>.json)
- Container managers config (75e81145-e85f-42ff-b992-d9d12c865c0e.json) get from iHost, see steps below.

Information needed:

- Unix timestamp of when the image was created
- File location (if required by the container) to save files internally.
- The image Repository name and version (Tag)

Step:

1. Login to iHost
2. On the left go to the System/RTU you wish to update.
3. Click on the 'Upload files' button
4. Upload:
 - a. Folder – 'containers'
 - b. Should not need to tick the Overwrite radio button
 - c. Choose the image file
 - d. Fill in the description
 - e. Click upload
5. Repeat the above for the New images Config as well
6. Before uploading the Container manager config:
 - a. Go to 'Files' -> 'containers' folder
 - i. You should now see your new <IID>.tar file and <IID>.json files

- ii. Convert the date created for the <IID>.tar file to a Unix timestamp and confirm it's the same as (or newer) what you have. The image timestamp in the Container manager's config should be older than what is in iHost.
- b. Download and Update the Container Managers 'Containers' array with the new containers information:

```
{  
  "containerName": "<IID>",  
  "File": "<IID>.tar",  
  "imageTimestamp": <The timestamp from step 6>,  
  "DockerParams": {  
    "containerName": "<IID>",  
    "imageID": "<IID Repository>:<Version/Tag>",  
    "containerVolume": </full/path/to/data/folder>,"  
    "containerPrivileged": false  
  }  
}
```

Table 1 - Image JSON object for the Container Managers Config

- c. Extra information can be found in the Public API Document
 - d. Save the file and overwrite the original.
 - e. Follow step 4 and upload the new Container Manager config file, but click the 'Overwrite' radio button
7. After a few cycles of the Comms Container checking iHost and status/request cycles the container will be downloaded with its config and started.

Update Image upload

Files needed:

- Updated Image file to be uploaded (<IID>.tar)
- The updated Image config (<IID>.json) if needed
- Container managers config (75e81145-e85f-42ff-b992-d9d12c865c0e.json) get from iHost see steps below.

Information needed:

- Unix timestamp of when the image was created
- File location (if required by the container) to save files internally.
- The image Repository name and version (Tag)

Step:

1. Login to iHost
2. On the left go to the System/RTU you wish to update.
3. Click on the 'Upload files' button
4. Upload:
 - a. Folder – 'containers'
 - b. Will need to tick the Overwrite radio button
 - c. Choose the image file
 - d. Fill in the description
 - e. Click upload
5. Repeat the above for the New images Config as well only if needed
6. Before uploading the Container manager config:
 - a. Go to 'Files' -> 'containers' folder
 - i. You should now see your new <IID>.tar file and <IID>.json files
 - ii. Convert the date created for the <IID>.tar file to a Unix timestamp and confirm it's the same as (or newer) what you have. The image timestamp in the Container manager's config has to be older than what is in iHost.
 - b. Download and Update the Container Managers 'Containers' array with the updated containers information:
 - i. Only change the:
 1. imageTimestamp
 2. imageID
 3. containerVolume (If Changed) See Table 1 above
 - c. Extra information can be found in the Public API Document
 - d. Save the file and overwrite the original.
 - e. Follow step 4 and upload the new Container Manager config file
7. After a few cycles of the Comms Container checking iHost and status/request cycles the container will be downloaded with its config and started.

Update Container Config

Files needed:

- The updated Image config (<IID>.json)

Steps:

1. Login to iHost
2. On the left go to the System/RTU you wish to update.
3. Click on the 'Upload files' button
4. Upload:
 - a. Folder – 'containers'
 - b. Will need to tick the Overwrite radio button
 - c. Choose the config file (<IID>.json)
 - d. Fill in the description
 - e. Click upload

- After a few cycles of the Comms Container checking iHost the config will be downloaded and sent out by the Container Manager

Errno Output

MQTT Topic

storage/data/error/75e81145-e85f-42ff-b992-d9d12c865c0e

Errno Table

Err no	Name – inside	Description
10	MQTT_SUBSCRIBE_ERRNO	Used when trying to subscribe to a topic and it fails.
11	FILE_MANAGER_FAILED_MOVE	A failed move of either a config file or a .tar (Container Image) file. From (Generally but this can change) /tmp/LVCAP_config or /tmp/LVCAP_image to /home/CM/LVCAP_config or /home/CM/LVCAP_image In V7 not used.
12	JSON_PARSE_ERROR_FILE	A failed read of the Container Managers config from file.
13	FILE_MANAGER_READ_ERROR	A failed attempt at opening or reading a file on the system.
14	FILE_MANAGER_WRITE_BAD	After a successful open of the file, it fails writing data to the file.
15	FILE_MANAGER_WRITE_NOT_OPEN	A failed attempt at opening a file to write to.
16	FILE_MANAGER_COPY_BAD	After a successful open of the file the write of the copied data is bad.
17	FILE_MANAGER_COPY_FILE_NOT_EQ UAL	The check that each file is the same size fails

Err no	Name – inside	Description
18	FILE_MANAGER_COPY_NOT_OPEN	Could not open the destination file to copy to.
19	FILE_MANAGER_IMAGE_MOVE_ERROR	After trying to move an Image file (.tar) the file does not exist at the intended destination.
20	MQTT_MANAGER_STATUS_MSG_ERROR	Error parsing the JSON message from any status/response/<GUID> topic
21	FILE_MANAGER_MKDIR	Can be multiple different causes. <ul style="list-style-type: none"> • ENAMETOOLONG • ENOSPC • ENOTDIR • EACCES For more information see: http://pubs.opengroup.org/onlinepubs/009695399/functions/mkdir.html
22	MQTT_MANAGER_STATUS_KEY_ERROR	The status JSON Payload is correct but is missing the Key "Status" or the value it holds in not an integer.
23	MQTT_MANAGER_STATUS_DEFAULT_ERROR	The status Integer does not match any that is present in the External API Document.
26	MQTT_MANAGER_CONFIG_MSG_PARSE_ERROR	Not used?
27	MQTT_MANAGER_TP_CONF_FILE_ERROR	If a Container config (Not the Container Managers) is empty or invalid JSON.
29	MQTT_MANAGER_TP_CONF_KEY_ERROR	No Key "ContainerConfig" found in the config, or the value does not contain a JSON Object
30	MQTT_MANAGER_INCOMING_STATUS_FAIL	Status Fail was sent by a running container.
31	MQTT_MANAGER_INCOMING_STATUS_ERROR	Status Error was sent by a running container.
32	MQTT_MANAGER_INCOMING_STATUS_SHUT_DWN	Status Shut Down was sent by a running container

Err no	Name – inside	Description
33	MQTT_MANAGER_CONFIG_DWN_LOAD_MSG_ERROR	The notification payload for a new config downloaded is empty or invalid JSON.
35	MQTT_MANAGER_CONFIG_DWNLD_EMPTY_FILE	The downloaded config is empty or invalid JSON
36	MQTT_MANAGER_CONFIG_DWNLD_NOT_USED	The file was found and valid JSON but the contents does not match what is needed for Container or the Manager. This is then logged as it is not used.
37	MQTT_MANAGER_CONFIG_DWNLD_CONTENTS	Config downloaded notification message not empty & valid JSON but does not contain correct Key/Value as a downloaded file.
38	DOCKER_INTERFACE_PROCESS_CONTAINERS	Processing the containers inside the Container Managers config. This is if the config is not valid JSON or empty.
39	DOCKER_INTERFACE_START_CONTAINERS	A failed start of a container. This is trying to start a pre-loaded container.
40	DOCKER_INTERFACE_STOP_CONTAINERS	A failed stop of a running container.
41	DOCKER_INTERFACE_RESTART_CONTAINER	A failed restart of a container.
42	DOCKER_INTERFACE_LOAD_CONTAINER	A failed Load of an docker image.
43	DOCKER_INTERFACE_PARSE_CMD	Running a command failed to parse the response.
44	DOCKER_INTERFACE_FAILED_STATUS_REPLY	Container has failed to respond to status/request and is to be shutdown.
50	SYSTEM_COMMAND_POPEN_ERROR	Error doing popen(), failed to fork / pipe / malloc etc.
51	SYSTEM_COMMAND_PCLOSE_ERROR	Error back from pclose(), the process died on a signal etc.

Appendix G. Load profile test

The aim of the Load Profile configuration is to produce a predicted half hourly load current forecast for the next 24 hours. The method adopted for each half hour is to calculate the RMS load during the same half hour on the same day of the week in the previous four weeks. Thus the forecast for 00:00 to 00:30 on day twenty-nine is calculated as the RMS of the load currents between 00:00 and 00:30 on days one, eight, fifteen, twenty-two. The calculations are carried out per-phase for each of the three phases.

Inputs

The Application will take its data input by subscribing to MQTT topics

sensor/data/96d6f19b-7022-45f2-b753-cb5012626b4d/gridkey-mcu520/60/feeder/1/I1/current-mean

sensor/data/96d6f19b-7022-45f2-b753-cb5012626b4d/gridkey-mcu520/60/feeder/1/I2/current-mean

sensor/data/96d6f19b-7022-45f2-b753-cb5012626b4d/gridkey-mcu520/60/feeder/1/I3/current-mean

Payloads in Scalar Object Format (as defined in API section 9.1) will be published on these topics every 60 seconds, containing the measured RMS load current in each phase in Amps (API section 4.5). This is the measurement data from the Lucy GridKey Sensor Application

For testing data will be sent on the same topics but in faster than real time. The following data will be sent, the same for each day on each phase:

- L1: Load Curve G, peak current 100A
- L2: Load Curve 33A, peak current 200A
- L3: Constant current of 300A

This data is contained in the 28 day input data file input-28day.csv and the 1 day input data file which follows it input-1day-w5d1.csv.

Procedure for creating the test data set (for reference only, use above files for testing).

10. Open ODF data generator spreadsheet in LibreOffice Calc
11. Adjust settings to set desired curves, peak currents and start date/time (in UTC)
12. Make sure export sheet is selected sheet.
13. File > Save a Copy ...
14. Change Save as type to Text CSV
15. Enter file name and click Save
16. In export dialogue:
 - a. Character set: Western Europe
 - b. Field delimiter: ,
 - c. Text delimiter: "
 - d. Tick Save cell content as shown and untick the others
 - e. Click OK
17. When it warns only the selected sheet was saved, click OK.

18. This produces a 7 day input file, repeat for more days and edit files together, or chop out the required section for shorter files.

To feed the 28 day input into the system at 3600 times real time (one hour per second) use the command

```
./play_csv.py --host marketplace --port 8883 --cafile broker-ca.pem --cert eatl_tlsdevtools.crt  
--key eatl_tlsdevtools.key --no-store -i input-28day.csv -f 3600
```

To feed the 1 day input into the system at 60 times real time (one minute per second) use the command

```
./play_csv.py --host marketplace --port 8883 --cafile broker-ca.pem --cert eatl_tlsdevtools.crt  
--key eatl_tlsdevtools.key --no-store -i input-1day-w5d1.csv -f 3600
```

Configuration

Reference: 2662-MANUL-S001-Vxx.yy.zz

For the Load Profiler the following global settings are used:

Debug: true (turn debug output on)

RefreshRate: 2 (This determines how often outputs can be produced. This setting is in real time regardless of the timestamps in input data).

MaxDataWait: 300 (Data will come in much more often than this in testing).

One profile is configured:

ProfileName: PredictedTxLoad (name for output data)

ProfileCircuit: Transformer(what is this for?)

ProfileTimeSlotAlgorithm: SquaredAverage (we want to use the RMS / geometric mean of the load current values to give the correct heating effects in rating calculations).

ProfileLateDataLimitInSeconds: 120 (we will be feeding in 60 second interval data)

ProfileDailyTimeSlots: 48 (to give 30 minute interval slots)

ProfileWindowLengthDays: 28

Inputs:

value: sensor/data/96d6f19b-7022-45f2-b753-cb5012626b4d/gridkey-mcu520/60/feeder/1/l1/current-mean

value: sensor/data/96d6f19b-7022-45f2-b753-cb5012626b4d/gridkey-mcu520/60/feeder/1/l2/current-mean

value: sensor/data/96d6f19b-7022-45f2-b753-cb5012626b4d/gridkey-mcu520/60/feeder/1/l3/current-mean (three inputs for three phases, from the sensors defined above)

Output Settings:

ProfileOutputTopicString: "tx-load/predict/byday/l1/30/30/1440" (name of the sub-topic the data will be published on)

ProfileOutputIntervalMinutes: 30 (output a new profile every 30 minutes)

ProfileOutputPredictionLengthMinutes: 1440 (24 hour prediction)

ProfileOutputSmoothing: RMS (we want to calculate the RMS / geometric mean of the days)

ProfileOutputValues: value: sensor/data/96d6f19b-7022-45f2-b753-cb5012626b4d/gridkey-mcu520/60/feeder/1/l1/current-mean (only one input, from the sensor defined above)

The same arrangement is repeated for I2 and I3.

LV-CAP is configured to run the Load Profiler and CSV logger applications only. The CSV logger is configured to log the sensor topics to a single CSV file

Outputs

The output profiles must be published on the topics:

- algorithm/data/5414c8fd-4924-4d08-a56a-c7e553b40e3e/tx-load/predict/byday/l1/30/30/1440
- algorithm/data/5414c8fd-4924-4d08-a56a-c7e553b40e3e/tx-load/predict/byday/l2/30/30/1440
- algorithm/data/5414c8fd-4924-4d08-a56a-c7e553b40e3e/tx-load/predict/byday/l3/30/30/1440

The Application must publish profiles in the standard LV-CAP time series JSON format to the above MQTT topic. Each profile produced must start at approximately the current time (based upon the time stamps of the incoming data, not the host system clock). Each profile produced will have 48 elements, each of 30 minutes duration.

To convert timestamps into human-readable UTC time use a command line

```
date -u -d '@1503966600' "+%Y/%m/%d %H:%M:%S %Z"
```

Test Steps

9. Start from a clean LV-CAP core system with no data files or load profile data present.
10. Deploy the TLS Development tools, which include the play_csv.py script. Install any necessary python packages to run the script against the LV-CAP core.
11. Deploy and configure the Load Profiler and Data Storage applications onto the system.
12. Use make sub-sensor to monitor sensor data on the system
13. Play the 28-day history file into the system to build up the profile data (this takes ~12 minutes):
./play_csv.py --host marketplace --port 8883 --cafile broker-ca.pem --cert eatl_tlsdevtools.crt --key eatl_tlsdevtools.key --no-store -i input-28day.csv -f 3600
14. When the 28-day data set completes, also monitor the algorithm output with make sub-alg
15. Continue to play back the 1 day file at slower speed to see the profiles being produced:
./play_csv.py --host marketplace --port 8883 --cafile broker-ca.pem --cert

```
eatl_tlsdevtools.crt --key eatl_tlsdevtools.key --no-store -i input-1day-w5d1.csv -f  
3600
```

16. Examine the profiles produced and check as documented below.

Expected Outputs

The 1 day data file we are using for testing contains data for Tue 29 Aug 2017, so we are looking for the outputs from this day to be produced.

The first three outputs will be produced almost immediately, for I1, I2 and I3 respectively.

- Each will have the same TimeStamp values of 1503966600, which is 2017/08/29 00:30:00 UTC, the first profile of the day.
- TimeStampStart will have a value of 1501547400, which is 2017/08/01 00:30:00 UTC, the date and time 28 days earlier when the oldest data used in the profile was collected.
- On the L1 output, the values are for load curve G at 100A peak, which starts with an hour of 100A, then 96.8A for the next hour and then 93A, ending up with a hour of 99.2A
- On the L2 output, the values are for load curve 33A at 200A peak, which starts with 187A for one hour (two profile steps), then 177.4A and 168.2A, ending up at 200A
- On the L3 output, the values are all 300A because the load does not change!

Now move on to the second set of profiles produced.

- Each will have a TimeStamp value of 1503968400, which is 2017/08/29 01:00:00 UTC, half an hour after the previous profiles.
- TimeStampStart has also moved on to 1501549200 (2017/08/01 01:00:00 UTC).
- On L1 output, things have moved up by half a hour, so we get only one step at 100A, two each at 96.8A and 93A. We end with two at 99.2A and then the 100A value wrapped from the start.
- The same on L2, one step at 187A, two each at 177.4A and 168.2A, ending with two at 200A and one at 187A
- On the L3 output, the values are all 300A because the load does not change!

We can keep doing this for as long as you like, but you get the picture!

Appendix H. Data Reading Test

Configuration

Configure the Modbus RTU Sensor Application to read all the identified registers to the topics as given in 2404-RQSPEC-S002, except that any parameter configured to read less often than every 60 seconds should be re-configured to read every 60 seconds. This configuration file ...

Configure the CSV Data Recorder Application to record the values of all parameters read from each of the three circuit breakers every 10 seconds to one file prefixed "ALVIN_load", and all other parameters (read from each of the three circuit breakers every 60 seconds) to a second file prefixed "ALVIN_status". The configuration file ...

Switch the ALVIN control switch on the front of the OpenLV Enclosure to the ON position.

Ensure that the Circuit Breakers are in the closed position.

Set up a voltmeter within the test enclosure to measure the L1 phase to neutral voltage, and a CT and ammeter to measure the L1 load current.

Test Steps

1. Apply power to the CBs and pass load current through them.
2. Switch the ALVIN control switch on the front of the OpenLV Enclosure to the ON position.
3. Run the command `make sub-alvin-load` in the LV-CAP TLS development tools directory.
4. Verify that, every 10 seconds, output are produced, on the following topics:
 - a. `sensor/data/eatl_sensorcontainer_00/feeder1/l1/busbar_voltage`
 - b. `sensor/data/eatl_sensorcontainer_00/feeder1/l1/cable_voltage`
 - c. `sensor/data/eatl_sensorcontainer_00/feeder1/l1/load_current`
 - d. `sensor/data/eatl_sensorcontainer_00/feeder1/l1/reactive_power`
 - e. `sensor/data/eatl_sensorcontainer_00/feeder1/l1/active_power`
5. Examine the contents of the ALVIN_load CSV file and confirm that it contains a line every 10 seconds and a total of 31 columns (timestamp, 5 data points and 5 valid flags for each phase).
6. Confirm that the `busbar_voltage` and `cable_voltage` topics show the same voltage as the voltmeter.
7. Confirm that the `load_current` topic shows the same current as the ammeter.
8. Run the command `make sub-alvin-status` in the LV-CAP TLS development tools directory.

9. Verify that every 60 seconds, output are produced, on the following topics:
 - a. sensor/data/eatl_sensorcontainer_00/feeder1/l1/open_operations
 - b. sensor/data/eatl_sensorcontainer_00/feeder1/l1/close_operations
 - c. sensor/data/eatl_sensorcontainer_00/feeder1/l1/watchdog_count
 - d. sensor/data/eatl_sensorcontainer_00/feeder1/l1/cpu_temperature
 - e. sensor/data/eatl_sensorcontainer_00/feeder1/l1/uptime
 - f. sensor/data/eatl_sensorcontainer_00/feeder1/l1/switch_temperature
 - g. sensor/data/eatl_sensorcontainer_00/feeder1/l1/fault_flags
10. Examine the contents of the ALVIN_status CSV file and confirm that it contains a line every 60 seconds and a total of 43 columns (timestamp, 7 data points and 7 valid flags).
11. Note the values of open_operations and close_operations and that they do not change.
12. Confirm that the cpu_temperature and switch_temperature are close to but above ambient temperature.
13. Confirm that the uptime value in seconds increments in real time.
14. Switch the ALVIN control switch on the front of the OpenLV Enclosure to the OFF position.
15. Run the command `make sub-alvin-load` in the LV-CAP TLS development tools directory.
16. Verify that, every 10 seconds, 15 lines of output are produced, 5 for each phase.
17. On L1 phase, verify that outputs are produced but with the Valid flag set to False on the following topics:
 - a. sensor/data/eatl_sensorcontainer_00/feeder1/l1/busbar_voltage
 - b. sensor/data/eatl_sensorcontainer_00/feeder1/l1/cable_voltage
 - c. sensor/data/eatl_sensorcontainer_00/feeder1/l1/load_current
 - d. sensor/data/eatl_sensorcontainer_00/feeder1/l1/reactive_power
 - e. sensor/data/eatl_sensorcontainer_00/feeder1/l1/active_power
18. Run the command `make sub-alvin-status` in the LV-CAP TLS development tools directory.
19. Verify that every 60 seconds, 21 lines of output are produced, 7 for each phase.
20. On L1 phase, verify that outputs are produced but with the Valid flag set to False on the following topics:
 - a. sensor/data/eatl_sensorcontainer_00/feeder1/l1/open_operations
 - b. sensor/data/eatl_sensorcontainer_00/feeder1/l1/close_operations
 - c. sensor/data/eatl_sensorcontainer_00/feeder1/l1/watchdog_count
 - d. sensor/data/eatl_sensorcontainer_00/feeder1/l1/cpu_temperature
 - e. sensor/data/eatl_sensorcontainer_00/feeder1/l1/uptime
 - f. sensor/data/eatl_sensorcontainer_00/feeder1/l1/switch_temperature
 - g. sensor/data/eatl_sensorcontainer_00/feeder1/l1/fault_flags

Appendix I. ALVIN Control Test

Configuration

Configure the Modbus RTU Sensor Application to control the ALVIN Reclose™ Circuit Breaker from the topic, 'sensor/data/1'.

Also configure it to read the value of the MHR_SHADOW_SWITCH_STATUS register in each CB every minute and log these three values to topics

- sensor/data/eatl_sensorcontainer_00/feeder1/l1/switch_state
- sensor/data/eatl_sensorcontainer_00/feeder1/l2/switch_state
- sensor/data/eatl_sensorcontainer_00/feeder1/l3/switch_state

Configure the CSV Data Recorder Application to record the values of the above algorithm topics to one file prefixed "ALVIN_command", and the sensor topics (read from each of the three circuit breakers every 60 seconds) to a second file prefixed ALVIN_result. The configuration file ...

Switch the ALVIN control switch on the front of the OpenLV Enclosure to the ON position.

Ensure that the Circuit Breaker is in the closed position.

Test Steps

1. Apply power to the CBs and pass load current through them.
2. Switch the ALVIN control switch on the front of the OpenLV Enclosure to the ON position.
3. Run the command `make pub-mesh-open-11` in the LV-CAP TLS development tools directory.
4. Observe that the L1 CB (only) opens. Note the time of this.
5. Wait at least one minute.
6. Run the command `make pub-mesh-close-11` in the LV-CAP TLS development tools directory.
7. Observe that the L1 CB (only) closes. Note the time of this.
8. Switch the ALVIN control switch on the front of the OpenLV Enclosure to the OFF position.
9. Run the command `make pub-mesh-open-11` in the LV-CAP TLS development tools directory.
10. Observe that none of the CBs opens, there is no change. Note the time of this.
11. Examine the contents of the ALVIN_command CSV file. Observe that both successful and unsuccessful commands are recorded at the times noted above.
12. Examine the contents of the ALVIN_result CSV file. Observe that only successful commands cause the ALVIN state to change at the times noted above.

Examine the contents of the ALVIN_status CSV file. Confirm that the values of open_operations and close_operations have increased from the ones noted before.

